



Schurch Asco SA



Partenaire et Savoir-faire

AV. DU 1ER MARS 33, CP 3052
CH-2001 NEUCHÂTEL
SUISSE

TÉL : +41 32 724 3434

FAX : +41 32 724 3436

EMAIL : INFO@SCHURCH-ASCO.COM

WEB : WWW.SCHURCH-ASCO.COM

1. GEWINDEBOHRER UND SCHNEIDEISEN

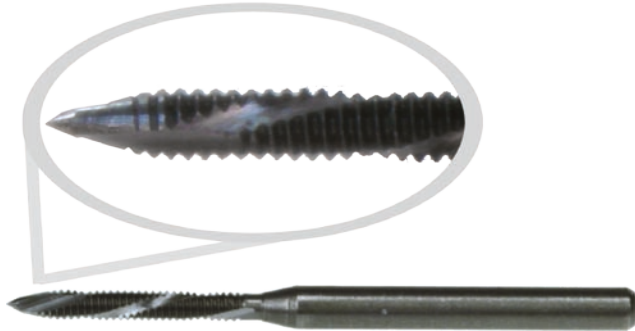

Maschinen-Gewindebohrer ASCO

für Uhrenindustrie und Apparatebau

Schnellstahl

SPIROLEX 10 / 3G NIHS

Für Durchgangslöcher in Messing. Mit 2 geschliffenen Schältnuten. Drall nach links bewirkt Spänetransport nach vorn, z.B. für Uhrenplatinen. Lieferbar auch mit langem Schaft für Maschine Hauser 570 oder Mehrspindelbohrkopf Emissa.

Ref.	Ø Nominal	Steigung	Ø Schaft	L Gesamt	L Schnitt	Ø Aussen	Ø Bohrung		Preis
							STAHL	MESSING	
01020	S 0.30	0.080	1.00	22	2.0	0.32	0.24	0.24	17.20
01021	S 0.35	0.090	1.00	22	2.0	0.37	0.28	0.28	17.20
01022	S 0.40	0.100	1.00	22	2.5	0.42	0.33	0.32	14.30
01023	S 0.50	0.125	1.00	22	3.0	0.52	0.43	0.40	14.30
01024	S 0.60	0.150	1.00	22	3.5	0.63	0.51	0.49	11.50
01025	S 0.70	0.175	1.50	25	4.5	0.73	0.59	0.57	7.50
01026	S 0.80	0.200	1.50	25	5.0	0.83	0.67	0.65	7.50
01027	S 0.90	0.225	1.50	25	5.5	0.93	0.75	0.73	7.50
01028	S 1.00	0.250	1.50	25	6.0	1.04	0.83	0.81	7.50
01029	S 1.10	0.250	1.50	25	7.0	1.14	0.93	0.91	7.50
01030	S 1.20	0.250	1.50	25	7.0	1.24	1.03	1.01	7.50
01031	S 1.30	0.300	1.50	25	8.0	1.34	1.09	1.07	7.50
01032	S 1.40	0.300	2.00	30	8.5	1.44	1.19	1.17	7.90
01033	S 1.50	0.300	2.00	30	10	1.54	1.29	1.27	7.90
01034	M 1.60	0.350	2.00	30	10	1.64	1.32	1.30	7.90
01035	M 1.70	0.350	2.00	30	10	1.74	1.42	1.40	7.90
01036	M 1.80	0.350	2.00	30	10	1.84	1.52	1.50	7.90
01037	M 2.00	0.400	3.00	35	13	2.07	1.68	1.65	8.60
01038	M 2.20	0.450	3.00	35	13	2.27	1.84	1.80	8.60
01039	M 2.30	0.400	3.00	35	13	2.37	1.98	1.95	8.60
01040	M 2.40	0.450	3.00	40	15	2.47	2.04	2.00	8.60
01041	M 2.50	0.450	3.00	40	15	2.57	2.14	2.10	8.60
01042	M 2.60	0.450	3.00	40	15	2.67	2.24	2.20	8.60
01043	M 3.00	0.500	4.00	40	16	3.09	2.60	2.50	10.00
01044	M 3.50	0.600	4.00	40	17	3.59	3.01	2.90	10.00
01045	M 4.00	0.700	5.00	50	20	4.10	3.42	3.30	11.50
01046	M 4.50	0.750	5.00	50	20	4.60	3.87	3.75	11.50
01047	M 5.00	0.800	6.00	55	25	5.10	4.35	4.20	12.90
01049	M 6.00	1.000	6.00	55	25	6.12	5.15	5.00	12.90

Verkaufsbedingungen: Der Rabatt oder der Zuschlag variiert je nach Menge und Schaftdurchmesser der identische Referenz der Bestellung.

	1.00 - 2.00	3.00	4.00	5.00 - 6.00	Bedingungen (%)
Menge (Stück)	1 - 19	1 - 9	1 - 4	1	+ 30
	20 - 99	10 - 49	5 - 24	2 - 9	netto
	100 - 199	50 - 99	25 - 49	10 - 19	- 20
	200 und +	100 und +	50 und +	20 und +	- 30

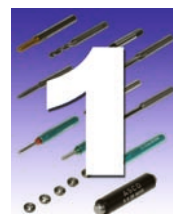

Maschinen-Gewindebohrer ASCO

für Uhrenindustrie und Apparatebau

Schnellstahl

SPIROLEX 20 / 3G NIHS

Für Durchgangslöcher in Dünnstahl. Mit 2 geschliffenen Spiralnuten. Drall nach links bewirkt Spänetransport nach vorn, z.B. für Stahlplattenen.



Ref.	Ø Nominal	Steigung	Ø Schaft	L Gesamt	L Schnitt	Ø Aussen	Ø Bohrung		Preis
							STAHL	MESSING	
01080	S 0.30	0.080	1.00	22	2.0	0.32	0.24	0.24	17.20
01081	S 0.35	0.090	1.00	22	2.0	0.37	0.28	0.28	17.20
01082	S 0.40	0.100	1.00	22	2.5	0.42	0.33	0.32	14.30
01083	S 0.50	0.125	1.00	22	3.0	0.52	0.43	0.40	14.30
01084	S 0.60	0.150	1.00	22	3.5	0.63	0.51	0.49	11.50
01085	S 0.70	0.175	1.50	25	4.5	0.73	0.59	0.57	7.50
01086	S 0.80	0.200	1.50	25	5.0	0.83	0.67	0.65	7.50
01087	S 0.90	0.225	1.50	25	5.5	0.93	0.75	0.73	7.50
01088	S 1.00	0.250	1.50	25	6.0	1.04	0.83	0.81	7.50
01089	S 1.10	0.250	1.50	25	7.0	1.14	0.93	0.91	7.50
01090	S 1.20	0.250	1.50	25	7.0	1.24	1.03	1.01	7.50
01091	S 1.30	0.300	1.50	25	8.0	1.34	1.09	1.07	7.50
01092	S 1.40	0.300	2.00	30	8.5	1.44	1.19	1.17	7.90
01093	S 1.50	0.300	2.00	30	10	1.54	1.29	1.27	7.90
01094	M 1.60	0.350	2.00	30	10	1.64	1.32	1.30	7.90
01095	M 1.70	0.350	2.00	30	10	1.74	1.42	1.40	7.90
01096	M 1.80	0.350	2.00	30	10	1.84	1.52	1.50	7.90
01097	M 2.00	0.400	3.00	35	13	2.07	1.68	1.65	8.60
01098	M 2.20	0.450	3.00	35	13	2.27	1.84	1.80	8.60
01099	M 2.30	0.400	3.00	35	13	2.37	1.98	1.95	8.60
01100	M 2.40	0.450	3.00	40	15	2.47	2.04	2.00	8.60
01101	M 2.50	0.450	3.00	40	15	2.57	2.14	2.10	8.60
01102	M 2.60	0.450	3.00	40	15	2.67	2.24	2.20	8.60
01103	M 3.00	0.500	4.00	40	16	3.09	2.60	2.50	10.00
01104	M 3.50	0.600	4.00	40	17	3.59	3.01	2.90	10.00
01105	M 4.00	0.700	5.00	50	20	4.10	3.42	3.30	11.50
01106	M 4.50	0.750	5.00	50	20	4.60	3.87	3.75	11.50
01107	M 5.00	0.800	6.00	55	25	5.10	4.35	4.20	12.90
01109	M 6.00	1.000	6.00	55	25	6.12	5.15	5.00	12.90

Verkaufsbedingungen: Der Rabatt oder der Zuschlag variiert je nach Menge und Schaftdurchmesser der identische Referenz der Bestellung.

	1.00 - 2.00	3.00	4.00	5.00 - 6.00	Bedingungen (%)
Menge (Stück)	1 - 19	1 - 9	1 - 4	1	+ 30
	20 - 99	10 - 49	5 - 24	2 - 9	netto
	100 - 199	50 - 99	25 - 49	10 - 19	- 20
	200 und +	100 und +	50 und +	20 und +	- 30



Schurch Asco SA



Partenaire et Savoir-faire

AV. DU 1ER MARS 33, CP 3052
CH-2001 NEUCHÂTEL
SUISSE

TÉL : +41 32 724 3434

FAX : +41 32 724 3436

EMAIL : INFO@SCHURCH-ASCO.COM

WEB : WWW.SCHURCH-ASCO.COM

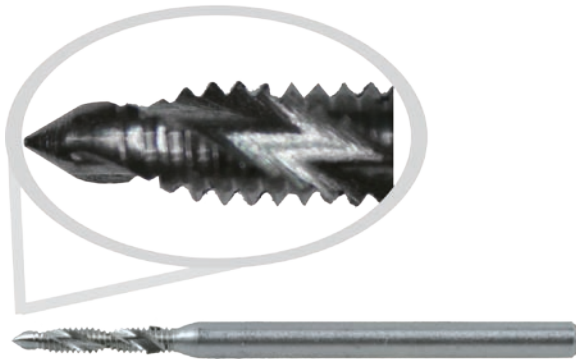

Maschinen-Gewindebohrer ASCO für Uhrenindustrie und Apparatebau Schnellstahl

SPIROLEX 30 / 3G NIHS

Für Messing: Sacklöcher mit 2 geschliffenen Spiralnuten.
Drall nach rechts, bewirkt Spänentransport nach hinten.
Für Drehautomaten oder Gewindeschneidmaschinen.
Lieferbar auch mit langem Schaft für Maschine Hauser
570 oder Bohrkopf Emissa (siehe Seite 16).

Ref.	Ø Nominal	Steigung	Ø Schaft	L Gesamt	L Schnitt	Ø Aussen	Ø Bohrung		Preis
							STAHL	MESSING	
01140	S 0.30	0.080	1.00	22	2.0	0.32	0.24	0.24	17.20
01141	S 0.35	0.090	1.00	22	2.0	0.37	0.28	0.28	17.20
01142	S 0.40	0.100	1.00	22	2.5	0.42	0.33	0.32	14.30
01143	S 0.50	0.125	1.00	22	3.0	0.52	0.43	0.40	14.30
01144	S 0.60	0.150	1.00	22	3.5	0.63	0.51	0.49	11.50
01145	S 0.70	0.175	1.50	25	4.5	0.73	0.59	0.57	7.50
01146	S 0.80	0.200	1.50	25	5.0	0.83	0.67	0.65	7.50
01147	S 0.90	0.225	1.50	25	5.5	0.93	0.75	0.73	7.50
01148	S 1.00	0.250	1.50	25	6.0	1.04	0.83	0.81	7.50
01149	S 1.10	0.250	1.50	25	7.0	1.14	0.93	0.91	7.50
01150	S 1.20	0.250	1.50	25	7.0	1.24	1.03	1.01	7.50
01151	S 1.30	0.300	1.50	25	8.0	1.34	1.09	1.07	7.50
01152	S 1.40	0.300	2.00	30	8.5	1.44	1.19	1.17	7.90
01153	S 1.50	0.300	2.00	30	10	1.54	1.29	1.27	7.90
01154	M 1.60	0.350	2.00	30	10	1.64	1.32	1.30	7.90
01155	M 1.70	0.350	2.00	30	10	1.74	1.42	1.40	7.90
01156	M 1.80	0.350	2.00	30	10	1.84	1.52	1.50	7.90
01157	M 2.00	0.400	3.00	35	13	2.07	1.68	1.65	8.60
01158	M 2.20	0.450	3.00	35	13	2.27	1.84	1.80	8.60
01159	M 2.30	0.400	3.00	35	13	2.37	1.98	1.95	8.60
01160	M 2.40	0.450	3.00	40	15	2.47	2.04	2.00	8.60
01161	M 2.50	0.450	3.00	40	15	2.57	2.14	2.10	8.60
01162	M 2.60	0.450	3.00	40	15	2.67	2.24	2.20	8.60
01163	M 3.00	0.500	4.00	40	16	3.09	2.60	2.50	10.00
01164	M 3.50	0.600	4.00	40	17	3.59	3.01	2.90	10.00
01165	M 4.00	0.700	5.00	50	20	4.10	3.42	3.30	11.50
01166	M 4.50	0.750	5.00	50	20	4.60	3.87	3.75	11.50
01167	M 5.00	0.800	6.00	55	25	5.10	4.35	4.20	12.90
01169	M 6.00	1.000	6.00	55	25	6.12	5.15	5.00	12.90

Verkaufsbedingungen: Der Rabatt oder der Zuschlag variiert je nach Menge und Schaftdurchmesser der identische Referenz der Bestellung.

	1.00 - 2.00	3.00	4.00	5.00 - 6.00	Bedingungen (%)
Menge (Stück)	1 - 19	1 - 9	1 - 4	1	+ 30
	20 - 99	10 - 49	5 - 24	2 - 9	netto
	100 - 199	50 - 99	25 - 49	10 - 19	- 20
	200 und +	100 und +	50 und +	20 und +	- 30

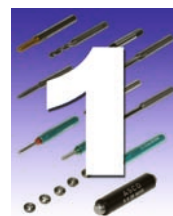

Maschinen-Gewindebohrer ASCO

für Uhrenindustrie und Apparatebau

Schnellstahl

SPIROLEX 35 / 3G NIHS

Für Durchgangs- oder Sacklöcher in Messing mit 2 geschliffenen Spiralnuten. Identisch mit No 30, jedoch ohne Spitze.

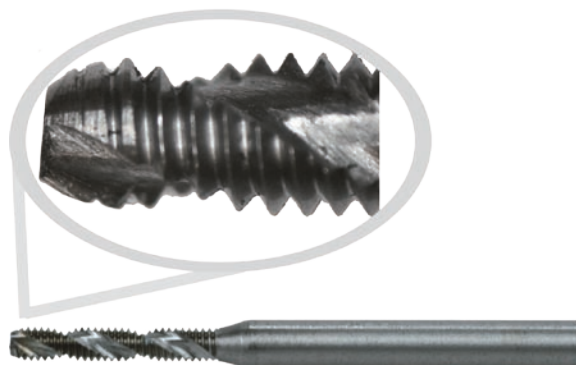

Ref.	Ø Nominal	Steigung	Ø Schaft	L Gesamt	L Schnitt	Ø Aussen	Ø Bohrung		Preis
							STAHL	MESSING	
01500	S 0.30	0.080	1.00	22	2.0	0.32	0.24	0.24	17.50
01501	S 0.35	0.090	1.00	22	2.0	0.37	0.28	0.28	17.50
01502	S 0.40	0.100	1.00	22	2.5	0.42	0.33	0.32	14.60
01503	S 0.50	0.125	1.00	22	3.0	0.52	0.43	0.40	14.60
01504	S 0.60	0.150	1.00	22	3.5	0.63	0.51	0.49	11.80
01505	S 0.70	0.175	1.50	25	4.5	0.73	0.59	0.57	7.80
01506	S 0.80	0.200	1.50	25	5.0	0.83	0.67	0.65	7.80
01507	S 0.90	0.225	1.50	25	5.5	0.93	0.75	0.73	7.80
01508	S 1.00	0.250	1.50	25	6.0	1.04	0.83	0.81	7.80
01509	S 1.10	0.250	1.50	25	7.0	1.14	0.93	0.91	7.80
01510	S 1.20	0.250	1.50	25	7.0	1.24	1.03	1.01	7.80
01511	S 1.30	0.300	1.50	25	8.0	1.34	1.09	1.07	7.80
01512	S 1.40	0.300	2.00	30	8.5	1.44	1.19	1.17	8.20
01513	S 1.50	0.300	2.00	30	10	1.54	1.29	1.27	8.20
01514	M 1.60	0.350	2.00	30	10	1.64	1.32	1.30	8.20
01515	M 1.70	0.350	2.00	30	10	1.74	1.42	1.40	8.20
01516	M 1.80	0.350	2.00	30	10	1.84	1.52	1.50	8.20
01517	M 2.00	0.400	3.00	35	13	2.07	1.68	1.65	8.90
01518	M 2.20	0.450	3.00	35	13	2.27	1.84	1.80	8.90
01519	M 2.30	0.400	3.00	35	13	2.37	1.98	1.95	8.90
01520	M 2.40	0.450	3.00	40	15	2.47	2.04	2.00	8.90
01521	M 2.50	0.450	3.00	40	15	2.57	2.14	2.10	8.90
01522	M 2.60	0.450	3.00	40	15	2.67	2.24	2.20	8.90
01523	M 3.00	0.500	4.00	40	16	3.09	2.60	2.50	10.30
01524	M 3.50	0.600	4.00	40	17	3.59	3.01	2.90	10.30
01525	M 4.00	0.700	5.00	50	20	4.10	3.42	3.30	11.80
01526	M 4.50	0.750	5.00	50	20	4.60	3.87	3.75	11.80
01527	M 5.00	0.800	6.00	55	25	5.10	4.35	4.20	13.20
01529	M 6.00	1.000	6.00	55	25	6.12	5.15	5.00	13.20

Verkaufsbedingungen: Der Rabatt oder der Zuschlag variiert je nach Menge und Schaftdurchmesser der identische Referenz der Bestellung.

Menge (Stück)	1.00 - 2.00	3.00	4.00	5.00 - 6.00	Bedingungen (%)
	1 - 19	1 - 9	1 - 4	1	+ 30
20 - 99	10 - 49	5 - 24	2 - 9	netto	
100 - 199	50 - 99	25 - 49	10 - 19	- 20	
200 et +	100 und +	50 und +	20 und +	- 30	



Schurch Asco SA



Partenaire et Savoir-faire

AV. DU 1ER MARS 33, CP 3052
CH-2001 NEUCHÂTEL
SUISSE

TÉL : +41 32 724 3434

FAX : +41 32 724 3436

EMAIL : INFO@SCHURCH-ASCO.COM

WEB : WWW.SCHURCH-ASCO.COM

Maschinen-Gewindebohrer ASCO

für Uhrenindustrie und Apparatebau

Schnellstahl

40 / 3G NIHS

Für Durchgangs- oder Sacklöcher in Messing. Mit 2 geraden, geschliffenen Nuten. Für Drehautomaten oder Gewindeschneidmaschinen.



Ref.	Ø Nominal	Steigung	Ø Schaft	L Gesamt	L Schnitt	Ø Aussen	Ø Bohrung		Preis
							STAHL	MESSING	
01200	S 0.30	0.080	1.00	22	2.0	0.32	0.24	0.24	17.20
01201	S 0.35	0.090	1.00	22	2.0	0.37	0.28	0.28	17.20
01202	S 0.40	0.100	1.00	22	2.5	0.42	0.33	0.32	14.30
01203	S 0.50	0.125	1.00	22	3.0	0.52	0.43	0.40	14.30
01204	S 0.60	0.150	1.00	22	3.5	0.63	0.51	0.49	11.50
01205	S 0.70	0.175	1.50	25	4.5	0.73	0.59	0.57	7.50
01206	S 0.80	0.200	1.50	25	5.0	0.83	0.67	0.65	7.50
01207	S 0.90	0.225	1.50	25	5.5	0.93	0.75	0.73	7.50
01208	S 1.00	0.250	1.50	25	6.0	1.04	0.83	0.81	7.50
01209	S 1.10	0.250	1.50	25	7.0	1.14	0.93	0.91	7.50
01210	S 1.20	0.250	1.50	25	7.0	1.24	1.03	1.01	7.50
01211	S 1.30	0.300	1.50	25	8.0	1.34	1.09	1.07	7.50
01212	S 1.40	0.300	2.00	30	8.5	1.44	1.19	1.17	7.90
01213	S 1.50	0.300	2.00	30	10	1.54	1.29	1.27	7.90
01214	M 1.60	0.350	2.00	30	10	1.64	1.32	1.30	7.90
01215	M 1.70	0.350	2.00	30	10	1.74	1.42	1.40	7.90
01216	M 1.80	0.350	2.00	30	10	1.84	1.52	1.50	7.90
01217	M 2.00	0.400	3.00	35	13	2.07	1.68	1.65	8.60
01218	M 2.20	0.450	3.00	35	13	2.27	1.84	1.80	8.60
01219	M 2.30	0.400	3.00	35	13	2.37	1.98	1.95	8.60
01220	M 2.40	0.450	3.00	40	15	2.47	2.04	2.00	8.60
01221	M 2.50	0.450	3.00	40	15	2.57	2.14	2.10	8.60
01222	M 2.60	0.450	3.00	40	15	2.67	2.24	2.20	8.60
01223	M 3.00	0.500	4.00	40	16	3.09	2.60	2.50	10.00
01224	M 3.50	0.600	4.00	40	17	3.59	3.01	2.90	10.00
01225	M 4.00	0.700	5.00	50	20	4.10	3.42	3.30	11.50
01226	M 4.50	0.750	5.00	50	20	4.60	3.87	3.75	11.50
01227	M 5.00	0.800	6.00	55	25	5.10	4.35	4.20	12.90
01229	M 6.00	1.000	6.00	55	25	6.12	5.15	5.00	12.90

Verkaufsbedingungen: Der Rabatt oder der Zuschlag variiert je nach Menge und Schaftdurchmesser der identische Referenz der Bestellung.

Menge (Stück)	1.00 - 2.00	3.00	4.00	5.00 - 6.00	Bedingungen (%)
		1 - 19	1 - 9	1 - 4	1
	20 - 99	10 - 49	5 - 24	2 - 9	netto
	100 - 199	50 - 99	25 - 49	10 - 19	- 20
	200 et +	100 und +	50 und +	20 und +	- 30



Maschinen-Gewindebohrer ASCO

für Uhrenindustrie und Apparatebau

Schnellstahl

50 / 3G NIHS

Für Durchgangs in Stahl. Mit 3 geraden, geschliffenen Nuten. Sehr bruchsicher. Für Drehautomaten oder Gewindeschneidmaschinen.

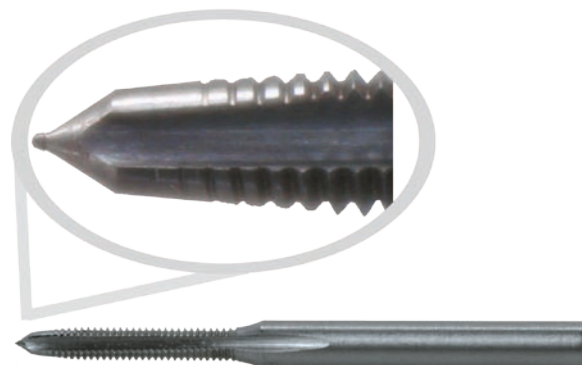

Ref.	Ø Nominal	Steigung	Ø Schaft	L Gesamt	L Schnitt	Ø Aussen	Ø Bohrung		Preis
							STAHL	MESSING	
01260	S 0.30	0.080	1.00	22	2.0	0.32	0.24	0.24	17.20
01261	S 0.35	0.090	1.00	22	2.0	0.37	0.28	0.28	17.20
01262	S 0.40	0.100	1.00	22	2.5	0.42	0.33	0.32	14.30
01263	S 0.50	0.125	1.00	22	3.0	0.52	0.43	0.40	14.30
01264	S 0.60	0.150	1.00	22	3.5	0.63	0.51	0.49	11.50
01265	S 0.70	0.175	1.50	25	4.5	0.73	0.59	0.57	7.50
01266	S 0.80	0.200	1.50	25	5.0	0.83	0.67	0.65	7.50
01267	S 0.90	0.225	1.50	25	5.5	0.93	0.75	0.73	7.50
01268	S 1.00	0.250	1.50	25	6.0	1.04	0.83	0.81	7.50
01269	S 1.10	0.250	1.50	25	7.0	1.14	0.93	0.91	7.50
01270	S 1.20	0.250	1.50	25	7.0	1.24	1.03	1.01	7.50
01271	S 1.30	0.300	1.50	25	8.0	1.34	1.09	1.07	7.50
01272	S 1.40	0.300	2.00	30	8.5	1.44	1.19	1.17	7.90
01273	S 1.50	0.300	2.00	30	10	1.54	1.29	1.27	7.90
01274	M 1.60	0.350	2.00	30	10	1.64	1.32	1.30	7.90
01275	M 1.70	0.350	2.00	30	10	1.74	1.42	1.40	7.90
01276	M 1.80	0.350	2.00	30	10	1.84	1.52	1.50	7.90
01277	M 2.00	0.400	3.00	35	13	2.07	1.68	1.65	8.60
01278	M 2.20	0.450	3.00	35	13	2.27	1.84	1.80	8.60
01279	M 2.30	0.400	3.00	35	13	2.37	1.98	1.95	8.60
01280	M 2.40	0.450	3.00	40	15	2.47	2.04	2.00	8.60
01281	M 2.50	0.450	3.00	40	15	2.57	2.14	2.10	8.60
01282	M 2.60	0.450	3.00	40	15	2.67	2.24	2.20	8.60
01283	M 3.00	0.500	4.00	40	16	3.09	2.60	2.50	10.00
01284	M 3.50	0.600	4.00	40	17	3.59	3.01	2.90	10.00
01285	M 4.00	0.700	5.00	50	20	4.10	3.42	3.30	11.50
01286	M 4.50	0.750	5.00	50	20	4.60	3.87	3.75	11.50
01287	M 5.00	0.800	6.00	55	25	5.10	4.35	4.20	12.90
01289	M 6.00	1.000	6.00	55	25	6.12	5.15	5.00	12.90

Verkaufsbedingungen: Der Rabatt oder der Zuschlag variiert je nach Menge und Schaftdurchmesser der identische Referenz der Bestellung.

Menge (Stück)	1.00 - 2.00	3.00	4.00	5.00 - 6.00	Bedingungen (%)
		1 - 19	1 - 9	1 - 4	1
	20 - 99	10 - 49	5 - 24	2 - 9	netto
	100 - 199	50 - 99	25 - 49	10 - 19	- 20
	200 und +	100 und +	50 und +	20 und +	- 30



Schurch Asco SA



Partenaire et Savoir-faire

AV. DU 1ER MARS 33, CP 3052
CH-2001 NEUCHÂTEL
SUISSE

TÉL : +41 32 724 3434

FAX : +41 32 724 3436

EMAIL : INFO@SCHURCH-ASCO.COM

WEB : WWW.SCHURCH-ASCO.COM

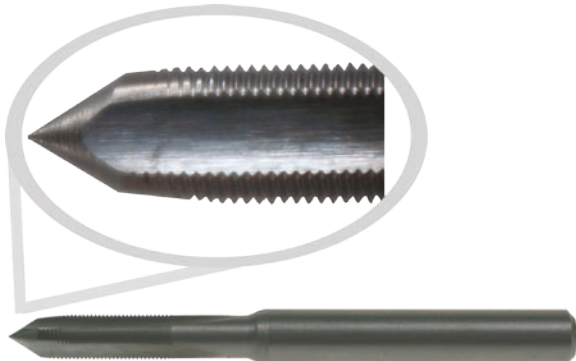

Maschinen-Gewindebohrer ASCO

Spezialprofile mit Feingewinde

HSSE/PM TYPE N ° 50

Für Stahl-, Durchgangs- oder Sacklöcher mit 3 geraden Nuten. Gute Bruchfestigkeit. Für Drehmaschine (Drehautomat) und Gewindeschneidmaschine.

Gewinde MF DIN 13 Feinsteigung

ISO 1-Toleranz: Schritt 0,08 => 1,00 ISO1 (4H)

ISO 2-Toleranz: Schritt 0,08 => 0,225 ISO2 (5H)

ISO 2-Toleranz: Schritt 0,25 => 1,00 ISO2 (6H)

Ref.	Ø Nominal	Steigung	Ø Schaft	L Gesamt	L Schnitt	Ø Aussen	Ø Bohrung	Preis
16813	M 0.80	0.10	1.50	25	5	0.83	0.65	17.20
16814	M 0.80	0.125	1.50	25	4	0.82	0.675	17.20
16815	M 0.80	0.15	1.50	25	5	0.82	0.70	17.20
16822	M 1.00	0.15	1.50	25	6	1.03	0.85	17.20
16823	M 1.00	0.20	1.50	25	6	1.03	0.80	17.20
16824	M 1.20	0.20	1.50	25	7	1.23	1.00	14.30
16825	M 1.20	0.15	1.50	25	7	1.23	1.05	14.30
16826	M 1.40	0.20	2.00	30	8.5	1.43	1.20	14.30
16827	M 1.40	0.25	2.00	30	8.5	1.44	1.15	14.30
16816	M 1.60	0.20	2.00	30	10	1.63	1.40	14.30
16817	M 1.60	0.25	2.00	30	10	1.64	1.35	14.30
16818	M 1.80	0.20	2.00	30	10	1.83	1.60	14.30
16819	M 1.80	0.25	2.00	30	10	1.84	1.55	14.30
16820	M 2.00	0.20	3.00	35	13	2.03	1.80	17.20
16821	M 2.00	0.25	3.00	35	13	2.04	1.75	17.20
16828	M 2.20	0.20	3.00	35	13	2.23	2.00	17.20
16829	M 2.20	0.25	3.00	35	13	2.24	1.95	17.20
16830	M 2.30	0.25	3.00	35	13	2.34	2.05	17.20
16831	M 2.40	0.20	3.00	35	13	2.44	2.20	17.20
16832	M 2.50	0.20	3.00	40	15	2.54	2.30	17.20
16833	M 2.50	0.25	3.00	40	15	2.54	2.25	17.20
16834	M 2.50	0.35	3.00	40	15	2.56	2.15	17.20
16835	M 2.80	0.25	3.00	40	15	2.83	2.55	17.20
16836	M 3.00	0.25	4.00	40	16	3.03	2.75	21.45
16837	M 3.00	0.30	4.00	40	16	3.03	2.70	21.45
16812	M 3.00	0.35	4.00	40	16	3.04	2.65	21.45
16811	M 3.50	0.25	4.00	40	16	3.54	3.25	21.45
16810	M 3.50	0.35	4.00	40	16	3.55	3.15	21.45

Verkaufsbedingungen : Der Rabatt oder der Zuschlag variiert je nach Menge und Schaftdurchmesser der identische Referenz der Bestellung.

Menge (Stück)	1.00 - 2.00	3.00	4.00	5.00 - 6.00	Bedingungen (%)
	1 - 19	1 - 9	1 - 4	1	+ 30
20 - 99	10 - 49	5 - 24	2 - 9	netto	
100 - 199	50 - 99	25 - 49	10 - 19	- 20	
200 und +	100 und +	50 und +	20 und +	- 30	



Maschinen-Gewindebohrer ASCO

für Uhrenindustrie und Apparatebau

Schnellstahl

60 / 3G NIHS

Für Durchgangs- oder Sacklöcher in Stahl. Mit 3 geraden geschliffenen Nuten. Kurzes Gewinde. Sehr bruchsicher. Für Drehautomaten oder Gewindeschneidmaschinen.



Ref.	Ø Nominal	Steigung	Ø Schaft	L Gesamt	L Schnitt	Ø Aussen	Ø Bohrung		Preis
							STAHL	MESSING	
01320	S 0.30	0.080	1.00	22	2.0	0.32	0.24	0.24	17.20
01321	S 0.35	0.090	1.00	22	2.0	0.37	0.28	0.28	17.20
01322	S 0.40	0.100	1.00	22	2.5	0.42	0.33	0.32	14.30
01323	S 0.50	0.125	1.00	22	3.0	0.52	0.43	0.40	14.30
01324	S 0.60	0.150	1.00	22	3.5	0.63	0.51	0.49	11.50
01325	S 0.70	0.175	1.50	25	4.5	0.73	0.59	0.57	7.50
01326	S 0.80	0.200	1.50	25	5.0	0.83	0.67	0.65	7.50
01327	S 0.90	0.225	1.50	25	5.5	0.93	0.75	0.73	7.50
01328	S 1.00	0.250	1.50	25	6.0	1.04	0.83	0.81	7.50
01329	S 1.10	0.250	1.50	25	7.0	1.14	0.93	0.91	7.50
01330	S 1.20	0.250	1.50	25	7.0	1.24	1.03	1.01	7.50
01331	S 1.30	0.300	1.50	25	8.0	1.34	1.09	1.07	7.50
01332	S 1.40	0.300	2.00	30	8.5	1.44	1.19	1.17	7.90
01333	S 1.50	0.300	2.00	30	10	1.54	1.29	1.27	7.90
01334	M 1.60	0.350	2.00	30	10	1.64	1.32	1.30	7.90
01335	M 1.70	0.350	2.00	30	10	1.74	1.42	1.40	7.90
01336	M 1.80	0.350	2.00	30	10	1.84	1.52	1.50	7.90
01337	M 2.00	0.400	3.00	35	13	2.07	1.68	1.65	8.60
01338	M 2.20	0.450	3.00	35	13	2.27	1.84	1.80	8.60
01339	M 2.30	0.400	3.00	35	13	2.37	1.98	1.95	8.60
01340	M 2.40	0.450	3.00	40	15	2.47	2.04	2.00	8.60
01341	M 2.50	0.450	3.00	40	15	2.57	2.14	2.10	8.60
01342	M 2.60	0.450	3.00	40	15	2.67	2.24	2.20	8.60
01343	M 3.00	0.500	4.00	40	16	3.09	2.60	2.50	10.00
01344	M 3.50	0.600	4.00	40	17	3.59	3.01	2.90	10.00
01345	M 4.00	0.700	5.00	50	20	4.10	3.42	3.30	11.50
01346	M 4.50	0.750	5.00	50	20	4.60	3.87	3.75	11.50
01347	M 5.00	0.800	6.00	55	25	5.10	4.35	4.20	12.90
01349	M 6.00	1.000	6.00	55	25	6.12	5.15	5.00	12.90

Verkaufsbedingungen: Der Rabatt oder der Zuschlag variiert je nach Menge und Schaftdurchmesser der identische Referenz der Bestellung.

Menge (Stück)	1.00 - 2.00	3.00	4.00	5.00 - 6.00	Bedingungen (%)
	1 - 19	1 - 9	1 - 4	1	
20 - 99	10 - 49	5 - 24	2 - 9	netto	
100 - 199	50 - 99	25 - 49	10 - 19	- 20	
200 et +	100 und +	50 und +	20 und +	- 30	



Schurch Asco SA



Partenaire et Savoir-faire

AV. DU 1ER MARS 33, CP 3052
CH-2001 NEUCHÂTEL
SUISSE

TÉL : +41 32 724 3434

FAX : +41 32 724 3436

EMAIL : INFO@SCHURCH-ASCO.COM

WEB : WWW.SCHURCH-ASCO.COM

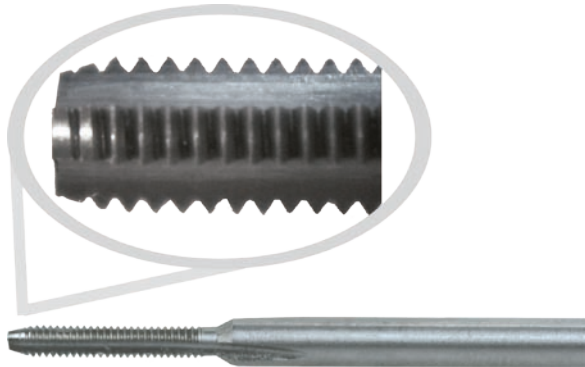

Maschinen-Gewindebohrer ASCO

für Uhrenindustrie und Apparatebau

Schnellstahl

65 / 3G NIHS

Für Sacklöcher in Stahl. Kurzes Gewinde. Für Gewinde bis auf den Grund. Mit 3 geraden geschliffenen Nuten, entspricht No 60, jedoch ohne Spitze. Für Drehautomaten, Federwellen oder Gewindeschneidmaschinen.

Ref.	Ø Nominal	Steigung	Ø Schaft	L Gesamt	L Schnitt	Ø Aussen	Ø Bohrung		Preis
							STAHL	MESSING	
01560	S 0.30	0.080	1.00	22	2.0	0.32	0.24	0.24	17.50
01561	S 0.35	0.090	1.00	22	2.0	0.37	0.28	0.28	17.50
01562	S 0.40	0.100	1.00	22	2.5	0.42	0.33	0.32	14.60
01563	S 0.50	0.125	1.00	22	3.0	0.52	0.43	0.40	14.60
01564	S 0.60	0.150	1.00	22	3.5	0.63	0.51	0.49	11.80
01565	S 0.70	0.175	1.50	25	4.5	0.73	0.59	0.57	7.80
01566	S 0.80	0.200	1.50	25	5.0	0.83	0.67	0.65	7.80
01567	S 0.90	0.225	1.50	25	5.5	0.93	0.75	0.73	7.80
01568	S 1.00	0.250	1.50	25	6.0	1.04	0.83	0.81	7.80
01569	S 1.10	0.250	1.50	25	7.0	1.14	0.93	0.91	7.80
01570	S 1.20	0.250	1.50	25	7.0	1.24	1.03	1.01	7.80
01571	S 1.30	0.300	1.50	25	8.0	1.34	1.09	1.07	7.80
01572	S 1.40	0.300	2.00	30	8.5	1.44	1.19	1.17	8.20
01573	S 1.50	0.300	2.00	30	10	1.54	1.29	1.27	8.20
01574	M 1.60	0.350	2.00	30	10	1.64	1.32	1.30	8.20
01575	M 1.70	0.350	2.00	30	10	1.74	1.42	1.40	8.20
01576	M 1.80	0.350	2.00	30	10	1.84	1.52	1.50	8.20
01577	M 2.00	0.400	3.00	35	13	2.07	1.68	1.65	8.90
01578	M 2.20	0.450	3.00	35	13	2.27	1.84	1.80	8.90
01579	M 2.30	0.400	3.00	35	13	2.37	1.98	1.95	8.90
01580	M 2.40	0.450	3.00	40	15	2.47	2.04	2.00	8.90
01581	M 2.50	0.450	3.00	40	15	2.57	2.14	2.10	8.90
01582	M 2.60	0.450	3.00	40	15	2.67	2.24	2.20	8.90
01583	M 3.00	0.500	4.00	40	16	3.09	2.60	2.50	10.30
01584	M 3.50	0.600	4.00	40	17	3.59	3.01	2.90	10.30
01585	M 4.00	0.700	5.00	50	20	4.10	3.42	3.30	11.80
01586	M 4.50	0.750	5.00	50	20	4.60	3.87	3.75	11.80
01587	M 5.00	0.800	6.00	55	25	5.10	4.35	4.20	13.20
01589	M 6.00	1.000	6.00	55	25	6.12	5.15	5.00	13.20

Verkaufsbedingungen: Der Rabatt oder der Zuschlag variiert je nach Menge und Schaftdurchmesser der identische Referenz der Bestellung.

Menge (Stück)	1.00 - 2.00	3.00	4.00	5.00 - 6.00	Bedingungen (%)
	1 - 19	1 - 9	1 - 4	1	
20 - 99	10 - 49	5 - 24	2 - 9	netto	
100 - 199	50 - 99	25 - 49	10 - 19	- 20	
200 und +	100 und +	50 und +	20 et +	- 30	



Rohlinge-Gewindebohrer ASCO

für Uhrenindustrie und Apparatebau
Gehärteter Schnellstahl

Dient zum Spänetransport, Polieren oder zur Steigungs-kontrolle.

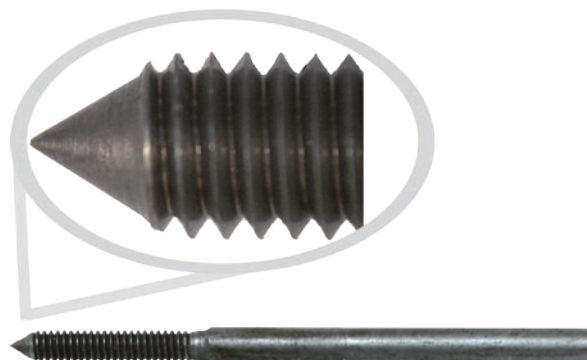

Ref.	Ø _{Nominal}	Steigung	Ø _{Schaft}	L _{Gesamt}	L _{Schnitt}	Ø _{Aussen}	Preis
01620	0.30	0.080	1.00	22	2.0	0.30	17.20
01621	0.35	0.090	1.00	22	2.0	0.35	17.20
01622	0.40	0.100	1.00	22	2.5	0.40	14.30
01623	0.50	0.125	1.00	22	3.0	0.50	14.30
01624	0.60	0.150	1.00	22	3.5	0.60	11.50
01625	0.70	0.175	1.50	25	4.5	0.70	7.50
01626	0.80	0.200	1.50	25	5.0	0.80	7.50
01627	0.90	0.225	1.50	25	5.5	0.90	7.50
01628	1.00	0.250	1.50	25	6.0	1.00	7.50
01629	1.10	0.250	1.50	25	7.0	1.10	7.50
01630	1.20	0.250	1.50	25	7.0	1.20	7.50
01631	1.30	0.300	1.50	25	8.0	1.30	7.50
01632	1.40	0.300	2.00	30	8.5	1.40	7.90
01633	1.50	0.300	2.00	30	10	1.50	7.90
01634	1.60	0.350	2.00	30	10	1.60	7.90
01635	1.70	0.350	2.00	30	10	1.70	7.90
01636	1.80	0.350	2.00	30	10	1.80	7.90
01637	2.00	0.400	3.00	35	13	2.00	8.60
01638	2.20	0.450	3.00	35	13	2.20	8.60
01639	2.30	0.400	3.00	35	13	2.30	8.60
01640	2.40	0.450	3.00	40	15	2.40	8.60
01641	2.50	0.450	3.00	40	15	2.50	8.60
01642	2.60	0.450	3.00	40	15	2.60	8.60
01643	3.00	0.500	4.00	40	16	3.00	10.00
01644	3.50	0.600	4.00	40	17	3.50	10.00
01645	4.00	0.700	5.00	50	20	4.00	11.50
01646	4.50	0.750	5.00	50	20	4.50	11.50
01647	5.00	0.800	6.00	55	25	5.00	12.90
01649	6.00	1.000	6.00	55	25	6.00	12.90

Verkaufsbedingungen: Der Rabatt oder der Zuschlag variiert je nach Menge und Schaftdurchmesser der identische Referenz der Bestellung.

Menge (Stück)	1.00 - 2.00	3.00	4.00	5.00 - 6.00	Bedingungen (%)
	1 - 19	1 - 9	1 - 4	1	+ 30
20 - 99	10 - 49	5 - 24	2 - 9	netto	
100 - 199	50 - 99	25 - 49	10 - 19	- 20	
200 und +	100 und +	50 und +	20 und +	- 30	



Schurch Asco SA



Partenaire et Savoir-faire

AV. DU 1ER MARS 33, CP 3052
CH-2001 NEUCHÂTEL
SUISSE

TÉL : +41 32 724 3434

FAX : +41 32 724 3436

EMAIL : INFO@SCHURCH-ASCO.COM

WEB : WWW.SCHURCH-ASCO.COM

Gewindebohrer ASCO für HAUSER 570

*für Uhrenindustrie und Apparatebau
mit langem Schaft*

10 / 3G NIHS

Für Durchgangslöcher in Messing. Mit 2 geschliffenen
Schälnten. Drall nach links, bewirkt Spänentransport nach
vorn, z.B. für Uhrenplatinen.

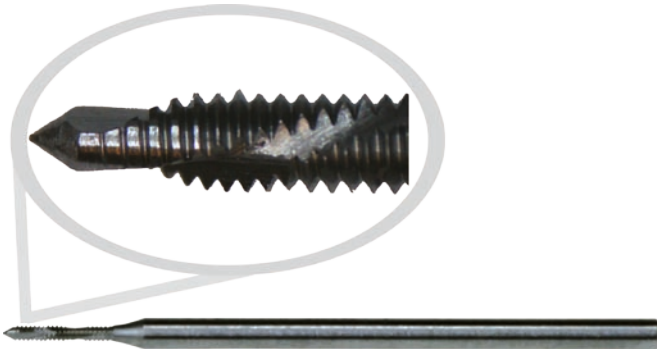

Ref.	Ø Nominal	Steigung	Ø Schaft	L Gesamt	L Schnitt	Ø Aussen	Ø Bohrung		Preis
							STAHL	MESSING	
01700	S 0.30	0.080	1.50	30	2.0	0.32	0.24	0.24	18.60
01701	S 0.35	0.090	1.50	30	2.0	0.37	0.28	0.28	18.60
01702	S 0.40	0.100	1.50	30	2.5	0.42	0.33	0.32	15.80
01704	S 0.50	0.125	1.50	30	3.0	0.52	0.43	0.40	15.80
01705	S 0.60	0.150	1.50	30	3.5	0.63	0.51	0.49	12.90
01706	S 0.70	0.175	1.50	30	4.5	0.73	0.59	0.57	8.90
01707	S 0.80	0.200	1.50	30	5.0	0.83	0.67	0.65	8.90
01708	S 0.90	0.225	1.50	30	5.5	0.93	0.75	0.73	8.90
01709	S 1.00	0.250	1.50	30	6.0	1.04	0.83	0.81	8.90
01710	S 1.10	0.250	1.50	30	7.0	1.14	0.93	0.91	8.90
01711	S 1.20	0.250	1.50	30	7.0	1.24	1.03	1.01	8.90
01712	S 1.30	0.300	1.50	30	8.0	1.34	1.09	1.07	8.90
01713	S 1.40	0.300	2.00	30	8.5	1.44	1.19	1.17	9.30
01714	S 1.50	0.300	2.00	30	10	1.54	1.29	1.27	9.30
01715	M 1.60	0.350	2.00	30	10	1.64	1.32	1.30	9.30
01716	M 1.70	0.350	2.00	30	10	1.74	1.42	1.40	9.30
01717	M 1.80	0.350	2.00	30	10	1.84	1.52	1.50	9.30
01718	M 2.00	0.400	3.00	35	13	2.07	1.68	1.65	10.00
01719	M 2.20	0.450	3.00	35	13	2.27	1.84	1.80	10.00
01720	M 2.30	0.400	3.00	35	13	2.37	1.98	1.95	10.00
01721	M 2.40	0.450	3.00	40	15	2.47	2.04	2.00	10.00
01722	M 2.50	0.450	3.00	40	15	2.57	2.14	2.10	10.00
01723	M 2.60	0.450	3.00	40	15	2.67	2.24	2.20	10.00
01724	M 3.00	0.500	4.00	40	16	3.09	2.60	2.50	11.50
01725	M 3.50	0.600	4.00	40	17	3.59	3.01	2.90	11.50
01726	M 4.00	0.700	5.00	50	20	4.10	3.42	3.30	12.90
01727	M 4.50	0.750	5.00	50	20	4.60	3.87	3.75	12.90
01728	M 5.00	0.800	6.00	55	25	5.10	4.35	4.20	14.30
01730	M 6.00	1.000	6.00	55	25	6.12	5.15	5.00	14.30

Verkaufsbedingungen: Der Rabatt oder der Zuschlag variiert je nach Menge und Schaftdurchmesser der identische Referenz der Bestellung.

Menge (Stück)	1.00 - 2.00	3.00	4.00	5.00 - 6.00	Bedingungen (%)
	1 - 19	1 - 9	1 - 4	1	
20 - 99	10 - 49	5 - 24	2 - 9	netto	
100 - 199	50 - 99	25 - 49	10 - 19	- 20	
200 und +	100 und +	50 und +	20 et +	- 30	

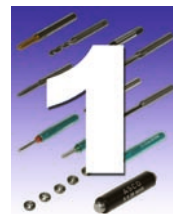

Druck-Gewindebohrer ROLL-STAR

Für Edelstahl, weiches Messing (nicht geeignet für normales Messing), Messing A61, Kupfer, Silber, Aluminium, Gold, etc.

Auf Anfrage Ausführung in 4HX, 5HX, 6HX, 5G, 6G.

Gewinde: NIHS

Toleranz: 3GX

Kern H5: Messing

Kern H6: Stahl

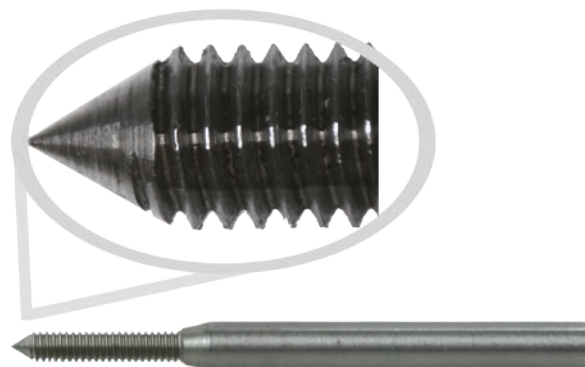

Ref.	Ø Nominal	Ø Schaft	L Gesamt	L Schnitt	Ø Aussen	Ø Bohrung	Ø Kern H5	Ø Kern H6	Preis
00858	S 0.40 x 0.100	1.5	25	2.0	0.42	0.35 - 0.37	0.330	0.342	17.20
00859	S 0.50 x 0.125	1.5	25	2.5	0.52	0.44 - 0.46	0.415	0.435	14.30
00860	S 0.60 x 0.150	1.5	25	3.0	0.63	0.53 - 0.55	0.502	0.522	14.30
00861	S 0.70 x 0.175	1.5	25	4.0	0.73	0.62 - 0.64	0.585	0.605	10.00
00862	S 0.80 x 0.200	1.5	25	4.0	0.83	0.70 - 0.72	0.665	0.685	10.00
00863	S 0.90 x 0.225	1.5	25	4.0	0.93	0.80 - 0.82	0.745	0.765	10.00
00864	S 1.00 x 0.250	1.5	25	5.0	1.04	0.90 - 0.93	0.825	0.845	10.00
00865	S 1.10 x 0.250	1.5	25	5.0	1.14	1.00 - 1.03	0.925	0.945	10.00
00866	S 1.20 x 0.250	1.5	25	5.0	1.24	1.10 - 1.13	1.025	1.045	10.00
00867	S 1.30 x 0.300	1.5	25	6.0	1.34	1.15 - 1.18	1.085	1.105	10.00
00868	S 1.40 x 0.300	2.0	30	6.0	1.44	1.25 - 1.28	1.185	1.205	10.80
00869	S 1.50 x 0.300	2.0	30	6.0	1.54	1.35 - 1.38	1.285	1.305	10.80
00870	M 1.60 x 0.350	2.0	30	8.0	1.64	1.45 - 1.48	1.221	0+100	10.80
00871	M 1.70 x 0.350	2.0	30	8.0	1.74	1.55 - 1.58	1.321	0+100	10.80
00872	M 1.80 x 0.350	2.0	30	8.0	1.84	1.65 - 1.68	1.421	0+100	10.80
00873	M 2.00 x 0.400	3.0	35	10	2.07	1.80 - 1.83	1.567	0+112	11.50
00874	M 2.20 x 0.450	3.0	35	10	2.28	2.00 - 2.03	1.713	0+125	11.50
00875	M 2.30 x 0.400	3.0	35	10	2.37	2.10 - 2.13	1.367	0+100	11.50
00876	M 2.50 x 0.450	3.0	35	10	2.57	2.30 - 2.33	2.013	0+125	11.50
00877	M 2.60 x 0.450	3.0	35	10	2.67	2.40 - 2.43	2.113	0+125	11.50
00878	M 3.00 x 0.500	4.0	40	12	3.09	2.75 - 2.78	2.459	0+140	12.90
00941	M 3.50 x 0.600	4.0	40	12	3.59	3.20 - 3.23	2.850	0+160	12.90
00942	M 4.00 x 0.700	5.0	50	16	4.10	3.65 - 3.68	3.242	0+180	14.30
00943	M 4.50 x 0.750	5.0	50	16	4.60	4.15 - 4.18	3.688	0+190	14.30

Verkaufsbedingungen: Der Rabatt oder der Zuschlag variiert je nach Menge und Schaftdurchmesser der identische Referenz der Bestellung.

Menge (Stück)	1.00 - 2.00	3.00	4.00	5.00 - 6.00	Bedingungen (%)
	1 - 19	1 - 9	1 - 4	1	+ 30
20 - 99	10 - 49	5 - 24	2 - 9	netto	
100 - 199	50 - 99	25 - 49	10 - 19	- 20	
200 et +	100 et +	50 und +	20 und +	- 30	



Schurch Asco SA



Partenaire et Savoir-faire

AV. DU 1ER MARS 33, CP 3052
CH-2001 NEUCHÂTEL
SUISSE

TÉL : +41 32 724 3434

FAX : +41 32 724 3436

EMAIL : INFO@SCHURCH-ASCO.COM

WEB : WWW.SCHURCH-ASCO.COM

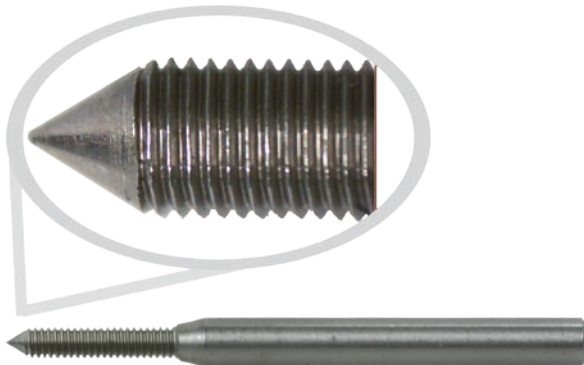

Druck-Gewindebohrer ROLL-STAR

Spezialprofil mit Feingewinde

Für Stahl-, Durchgangs- oder Sacklöcher mit 3 geraden Nuten. Gute Bruchfestigkeit. Für Drehmaschine (Drehautomat) und Gewindeschneidmaschine.

Gewinde MF DIN 13 Feinsteigung

ISO 1-Toleranz: Schritt 0,08 => 1,00 ISO1 (4H)

ISO 2-Toleranz: Schritt 0,08 => 0,225 ISO2 (5H)

ISO 2-Toleranz: Schritt 0,25 => 1,00 ISO2 (6H)

Ref.	Ø Nominal	STEIGUNG	Ø Aussen	Ø Schaft	L Gesamt	L Schnitt	Ø Bohrung	Ø Ader	Preis
16844	M 1.00	0.15	1.03	1.50	25	6	0.93 - 0.95	0.85	17.20
16845	M 1.00	0.20	1.03	1.50	25	6	0.90 - 0.92	0.80	17.20
16846	M 1.20	0.20	1.23	1.50	25	7	1.10 - 1.12	1.00	14.30
16847	M 1.20	0.15	1.23	1.50	25	7	1.13 - 1.15	1.05	14.30
16848	M 1.40	0.20	1.43	2.00	30	8.5	1.30 - 1.32	1.20	14.30
16849	M 1.40	0.25	1.44	2.00	30	8.5	1.28 - 1.30	1.15	14.30
16838	M 1.60	0.20	1.63	2.00	30	10	1.50 - 1.52	1.40	14.30
16839	M 1.60	0.25	1.64	2.00	30	10	1.48 - 1.50	1.35	14.30
16840	M 1.80	0.20	1.83	2.00	30	10	1.70 - 1.72	1.60	14.30
16841	M 1.80	0.25	1.84	2.00	30	10	1.68 - 1.70	1.55	14.30
16842	M 2.00	0.20	2.03	3.00	35	13	1.90 - 1.92	1.80	17.20
16843	M 2.00	0.25	2.04	3.00	35	13	1.88 - 1.90	1.75	17.20

Verkaufsbedingungen : Der Rabatt oder der Zuschlag variiert je nach Menge und Schaftdurchmesser der identische Referenz der Bestellung.

	1.00 - 2.00	3.00	4.00	5.00 - 6.00	Bedingungen (%)
Menge (Stück)	1 - 19	1 - 9	1 - 4	1	+ 30
	20 - 99	10 - 49	5 - 24	2 - 9	netto
	100 - 199	50 - 99	25 - 49	10 - 19	- 20
	200 und +	100 und +	50 und +	20 und +	- 30

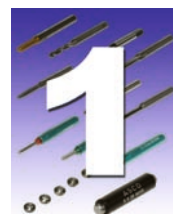

Druck-Gewindebohrer ROLL - WC/C

Für Edelstahl, weiches Messing, Messing A 61, Kupfer, Aluminium, Gold, Silber etc.

Auf Anfrage Ausführung in 4HX, 5HX, 6HX, 5G, 6G.

Gewinde: NIHS
Toleranz: 3GX
Kern H5: Messing
Kern H6: Stahl

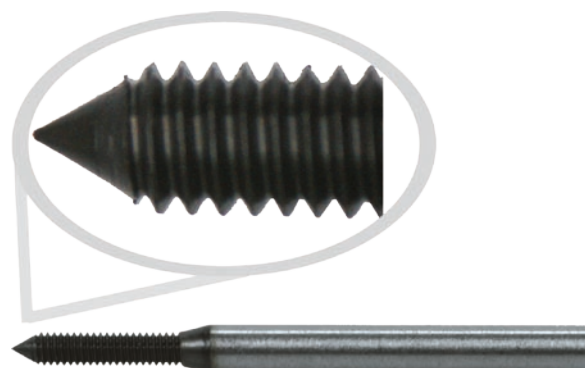

Ref.	Ø Nominal	Steigung	Ø Schaft	L Gesamt	L Schnitt	Ø Aussen	Ø Bohrung	Ø Kern H5	Ø Kern H6	Preis
00880	S 0.40	0.100	1.50 mm	25	2.0	0.42	0.35 - 0.37	0.330	0.342	23.30
00881	S 0.50	0.125	1.50 mm	25	2.5	0.52	0.44 - 0.46	0.415	0.435	23.30
00882	S 0.60	0.150	1.50 mm	25	3.0	0.63	0.53 - 0.55	0.502	0.522	23.30
00883	S 0.70	0.175	1.50 mm	25	4.0	0.73	0.62 - 0.64	0.585	0.605	19.00
00884	S 0.80	0.200	1.50 mm	25	4.0	0.83	0.70 - 0.72	0.665	0.685	19.00
00885	S 0.90	0.225	1.50 mm	25	4.0	0.93	0.80 - 0.82	0.745	0.765	19.00
00886	S 1.00	0.250	1.50 mm	25	5.0	1.04	0.90 - 0.93	0.825	0.845	19.00
00887	S 1.10	0.250	1.50 mm	25	5.0	1.14	1.00 - 1.03	0.925	0.945	19.00
00888	S 1.20	0.250	1.50 mm	25	5.0	1.24	1.10 - 1.13	1.025	1.045	19.00
00889	S 1.30	0.300	1.50 mm	25	6.0	1.34	1.15 - 1.18	1.085	1.105	19.00
00890	S 1.40	0.300	2.00 mm	30	6.0	1.44	1.25 - 1.28	1.185	1.205	19.80
00891	S 1.50	0.300	2.00 mm	30	6.0	1.54	1.35 - 1.38	1.285	1.305	19.80
00892	M 1.60	0.350	2.00 mm	30	8.0	1.64	1.45 - 1.48	1.221	0+100	19.80
00893	M 2.00	0.400	3.00 mm	35	10	2.07	1.80 - 1.83	1.567	0+112	21.90
00894	M 2.20	0.450	3.00 mm	35	10	2.28	2.00 - 2.03	1.713	0+125	21.90
00895	M 2.30	0.400	3.00 mm	35	10	2.37	2.10 - 2.13	1.367	0+100	21.90
00896	M 2.50	0.450	3.00 mm	35	10	2.57	2.30 - 2.33	2.013	0+125	21.90
00897	M 2.60	0.450	3.00 mm	35	10	2.67	2.40 - 2.43	2.113	0+125	21.90
00898	M 3.00	0.500	4.00 mm	40	12	3.09	2.75 - 2.78	2.459	0+140	21.90

Verkaufsbedingungen: Der Rabatt oder der Zuschlag variiert je nach Menge und Schaftdurchmesser der identische Referenz der Bestellung.

Menge (Stück)	1.00 - 2.00	3.00	4.00	5.00 - 6.00	Bedingungen (%)
	1 - 19	1 - 9	1 - 4	1	+ 30
20 - 99	10 - 49	5 - 24	2 - 9	netto	
100 - 199	50 - 99	25 - 49	10 - 19	- 20	
200 und +	100 und +	50 und +	20 und +	- 30	



Schurch Asco SA



Partenaire et Savoir-faire

AV. DU 1ER MARS 33, CP 3052
CH-2001 NEUCHÂTEL
SUISSE

TÉL : +41 32 724 3434

FAX : +41 32 724 3436

EMAIL : INFO@SCHURCH-ASCO.COM

WEB : WWW.SCHURCH-ASCO.COM

Druck-Gewindebohrer FORMER

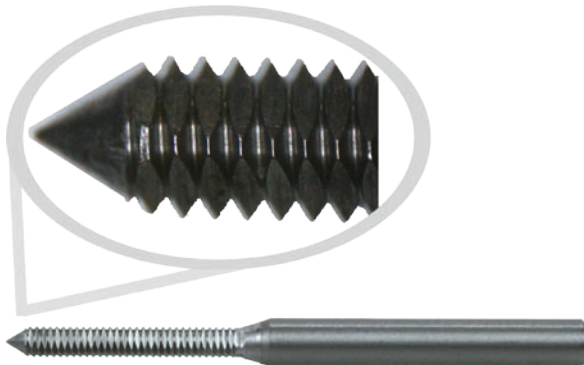

Gewinde: NIHS

Toleranz : 3GX

Anschnittlänge: 1.5 Gänge

Empfohlen für Stahl 20 AP und Edelstahl.

Kern H5: Messing

Kern H6: Stahl

Ref.	Ø Nominal	Ø Schaft	L Gesamt	L Schnitt	Ø Aussen	Ø Bohrung	Ø Kern H5	Ø Kern H5	Preis
00907	S 0.30 x 0.080 / 3GX	1.50	22	2.0	0.32	0.27 - 0.29	0.240	0.240	17.20
00908	S 0.35 x 0.090 / 3GX	1.50	22	2.0	0.37	0.31 - 0.33	0.286	0.286	17.20
00909	S 0.40 x 0.100 / 3GX	1.50	22	2.5	0.42	0.35 - 0.37	0.330	0.342	17.20
00910	S 0.50 x 0.125 / 3GX	1.50	22	3.0	0.52	0.44 - 0.46	0.415	0.435	17.20
00911	S 0.60 x 0.150 / 3GX	1.50	22	3.5	0.63	0.53 - 0.55	0.502	0.522	17.20
00912	S 0.70 x 0.175 / 3GX	1.50	25	4.5	0.73	0.62 - 0.64	0.585	0.605	8.90
00913	S 0.80 x 0.200 / 3GX	1.50	25	5.0	0.83	0.70 - 0.72	0.665	0.685	8.90
00914	S 0.90 x 0.225 / 3GX	1.50	25	5.5	0.93	0.80 - 0.82	0.745	0.765	8.90
00915	S 1.00 x 0.250 / 3GX	1.50	25	6.0	1.04	0.90 - 0.93	0.825	0.845	8.90
00916	S 1.10 x 0.250 / 3GX	1.50	25	7.0	1.14	1.00 - 1.03	0.925	0.945	8.90
00917	S 1.20 x 0.250 / 3GX	1.50	25	7.0	1.24	1.10 - 1.13	1.025	1.045	8.90
00918	S 1.30 x 0.300 / 3GX	1.50	25	8.0	1.34	1.15 - 1.18	1.085	1.105	8.90
00919	S 1.40 x 0.300 / 3GX	2.00	30	8.5	1.44	1.25 - 1.28	1.185	1.205	8.90
00920	S 1.50 x 0.300 / 3GX	2.00	30	10.0	1.54	1.35 - 1.38	1.285	1.305	8.90
00921	M 1.60 x 0.350 / 3GX	2.00	30	10.0	1.64	1.45 - 1.48	1.221	0+100	8.90
00922	M 1.70 x 0.350 / 3GX	2.00	30	10.0	1.74	1.55 - 1.58	1.321	0+100	8.90
00923	M 1.80 x 0.350 / 3GX	2.00	30	10.0	1.84	1.65 - 1.68	1.421	0+100	8.90
00924	M 2.00 x 0.400 / 3GX	3.00	35	13.0	2.07	1.80 - 1.83	1.567	0+112	10.00
00925	M 2.20 x 0.450 / 3GX	3.00	35	13.0	2.27	2.00 - 2.03	1.713	0+125	10.00
00926	M 2.30 x 0.400 / 3GX	3.00	35	13.0	2.37	2.10 - 2.13	1.367	0+100	10.00
00927	M 2.50 x 0.450 / 3GX	3.00	40	15.0	2.47	2.30 - 2.33	2.013	0+125	10.00
00928	M 2.60 x 0.450 / 3GX	3.00	40	15.0	2.57	2.40 - 2.43	2.113	0+125	10.00
00929	M 3.00 x 0.500 / 3GX	4.00	40	16.0	2.67	2.75 - 2.78	2.459	0+140	11.50
00930	M 3.50 x 0.600 / 3GX	4.00	40	17.0	3.09	3.20 - 3.23	2.850	0+160	11.50
00931	M 4.00 x 0.700 / 3GX	4.00	40	20.0	3.59	3.65 - 3.68	3.242	0+180	12.90
00932	M 4.50 x 0.750 / 3GX	5.00	50	20.0	4.10	4.15 - 4.18	3.688	0+190	12.90
00933	M 5.00 x 0.800 / 3GX	6.00	50	25.0	4.60	4.60 - 4.63	4.134	0+200	12.90
00934	M 5.50 x 0.900 / 3GX	6.00	55	25.0	5.10	5.10 - 5.13			12.90
00935	M 6.00 x 1.000 / 3GX	6.00	55	25.0	6.12	5.50 - 5.53			14.30

Verkaufsbedingungen: Der Rabatt oder der Zuschlag variiert je nach Menge und Schaftdurchmesser der identische Referenz der Bestellung.

Menge (Stück)	1.00 - 2.00	3.00	4.00	5.00 - 6.00	Bedingungen (%)
	1 - 19	1 - 9	1 - 4	1	
	20 - 99	10 - 49	5 - 24	2 - 9	netto
	100 - 199	50 - 99	25 - 49	10 - 19	- 20
	200 und +	100 und +	50 und +	20 und +	- 30

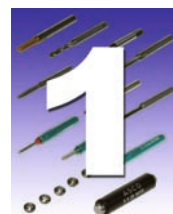

Druck-Gewindebohrer FORMER WC/C

Gewinde: NIHS
Toleranz: 3GX
Anschnittlänge: 1.5 Gänge

Empfohlen für Stahl 20 AP und Edelstahl.

Kern H5: Messing
Kern H6: Stahl



Ref.	Ø Nominal	Ø Schaft	L Gesamt	L Schnitt	Ø Aussen	Ø Bohrung	Ø Kern H5	Ø Kern H5	Preis
00976	S 0.30 x 0.080 / 3GX	1.50	22	2.0	0.32	0.27 - 0.29	0.240	0.240	26.15
00977	S 0.35 x 0.090 / 3GX	1.50	22	2.0	0.37	0.31 - 0.33	0.286	0.286	26.15
00978	S 0.40 x 0.100 / 3GX	1.50	22	2.5	0.42	0.35 - 0.37	0.330	0.342	26.15
00979	S 0.50 x 0.125 / 3GX	1.50	22	3.0	0.52	0.44 - 0.46	0.415	0.435	26.15
00980	S 0.60 x 0.150 / 3GX	1.50	22	3.5	0.63	0.53 - 0.55	0.502	0.522	26.15
00981	S 0.70 x 0.175 / 3GX	1.50	25	4.5	0.73	0.62 - 0.64	0.585	0.605	17.90
00982	S 0.80 x 0.200 / 3GX	1.50	25	5.0	0.83	0.70 - 0.72	0.665	0.685	17.90
00983	S 0.90 x 0.225 / 3GX	1.50	25	5.5	0.93	0.80 - 0.82	0.745	0.765	17.90
00984	S 1.00 x 0.250 / 3GX	1.50	25	6.0	1.04	0.90 - 0.93	0.825	0.845	17.90
00985	S 1.10 x 0.250 / 3GX	1.50	25	7.0	1.14	1.00 - 1.03	0.925	0.945	17.90
00986	S 1.20 x 0.250 / 3GX	1.50	25	7.0	1.24	1.10 - 1.13	1.025	1.045	17.90
00987	S 1.30 x 0.300 / 3GX	1.50	25	8.0	1.34	1.15 - 1.18	1.085	1.105	17.90
00988	S 1.40 x 0.300 / 3GX	2.00	30	8.5	1.44	1.25 - 1.28	1.185	1.205	19.00
00989	S 1.50 x 0.300 / 3GX	2.00	30	10.0	1.54	1.35 - 1.38	1.285	1.305	19.00
00990	M 1.60 x 0.350 / 3GX	2.00	30	10.0	1.64	1.45 - 1.48	1.221	0+100	19.00
00991	M 1.70 x 0.350 / 3GX	2.00	30	10.0	1.74	1.55 - 1.58	1.321	0+100	19.00
00992	M 1.80 x 0.350 / 3GX	2.00	30	10.0	1.84	1.65 - 1.68	1.421	0+100	19.00
00993	M 2.00 x 0.400 / 3GX	3.00	35	13.0	2.07	1.80 - 1.83	1.567	0+112	21.90
00994	M 2.20 x 0.450 / 3GX	3.00	35	13.0	2.28	2.00 - 2.03	1.713	0+125	21.90
00995	M 2.30 x 0.400 / 3GX	3.00	35	13.0	2.37	2.10 - 2.13	1.367	0+100	21.90
00996	M 2.50 x 0.450 / 3GX	3.00	40	15.0	2.57	2.30 - 2.33	2.013	0+125	21.90
00997	M 2.60 x 0.450 / 3GX	3.00	40	15.0	2.67	2.40 - 2.43	2.113	0+125	21.90
00998	M 3.00 x 0.500 / 3GX	4.00	40	16.0	3.09	2.75 - 2.78	2.459	0+140	21.90

Verkaufsbedingungen: Der Rabatt oder der Zuschlag variiert je nach Menge und Schaftdurchmesser der identische Referenz der Bestellung.

	1.00 - 2.00	3.00	4.00	5.00 - 6.00	Bedingungen (%)
Menge (Stück)	1 - 19	1 - 9	1 - 4	1	+ 30
	20 - 99	10 - 49	5 - 24	2 - 9	netto
	100 - 199	50 - 99	25 - 49	10 - 19	- 20
	200 und +	100 und +	50 und +	20 und +	- 30



Schurch Asco SA



Partenaire et Savoir-faire

AV. DU 1ER MARS 33, CP 3052
CH-2001 NEUCHÂTEL
SUISSE

TÉL : +41 32 724 3434

FAX : +41 32 724 3436

EMAIL : INFO@SCHURCH-ASCO.COM

WEB : WWW.SCHURCH-ASCO.COM

Druck-Gewindebohrer HI-ROLL

TYPE : NRT-OX

TYPE : W396046.9 HSS

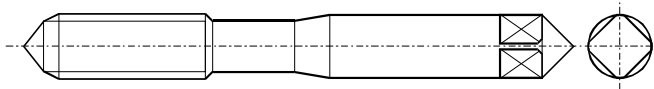

Spiralförmiges Polygonprofil

Oberflächenbehandlung .9 = OX = Dampf
(auf Anfrage B = ohne Behandlung)

Toleranz: 4HX / 5HX / 6HX / RH2 / RH3

Einlasslänge: 1,5 Gewinde / NRT-OX 2,5X

Empfohlen für:

Stahl für die Automatisierung 500 N/mm² Vc 16/20
m/min.

Edelstahl 850 N/mm² Vc 5/8 m/min.

Empfohlen für:

AUTOMATENSTAHL 500 N/MM2 VC 16/20 M/MIN.

EDELSTAHL 850 N/MM2 VC 5/8 M/MIN.

Ref.	Ø Nominal	Ø Schaft	L Gesamt	L Schnitt	Ø Bohrung	Preis
02269	M 0.50 X 0.125 / 4HX	1.5	20	2.0	0.43 - 0.44	67.50
02270	M 0.60 X 0.150 / 4HX	1.5	20	2.0	0.52 - 0.54	34.50
02271	M 0.70 X 0.175 / RH2 / NRT	3.0	30	2.2	0.60	33.90
02272	M 0.80 X 0.200 / 4HX	1.5	20	2.6	0.70 - 0.72	28.00
02273	M 0.90 X 0.225 / RH2 / NRT	3.0	30	3.0	0.80	24.80
02274	M 1.00 X 0.250 / RH3 / NRT	3.0	30	6.0	0.88	21.60
02275	M 1.20 X 0.250 / 5HX	3.0	32	6.0	1.09 - 1.11	19.70
02276	M 1.40 X 0.300 / 5HX	3.0	34	6.5	1.27 - 1.29	18.00
02277	M 1.60 X 0.350 / 6HX	3.0	36	7.0	1.45 - 1.47	17.50
02278	M 1.70 X 0.350 / 6HX	3.0	36	8.0	1.55 - 1.57	19.10
02279	M 1.80 X 0.350 / 6HX	3.0	36	8.0	1.65 - 1.67	19.10
02280	M 2.00 X 0.400 / 6HX	3.0	40	9.0	1.82 - 1.84	15.80
02283	M 2.50 X 0.450 / 6HX	3.0	44	11.0	2.31 - 2.34	13.80
02285	M 3.00 X 0.500 / 6HX	4.0	46	18.0	2.78 - 2.81	17.00

Verkaufsbedingungen: Rabatt von 5% für 10 identischen stücke.

22 Gewindebohrer und Schneideisen

Mai 2024



Micro-Gewindebohrer

1712 R

Vollhartmetall

Gewinde nach Norm NIHS
Schafttoleranz: h6
Empfohlen für nicht eisenhaltiges, leicht zu bearbeitendes Material, Durchgangslöcher mit einäugig und mit 3 geraden, geschliffenen Nuten.



Ref.	TOLE-RANZ	NIHS	STEI-GUNG	Ø Schaft	L Gesamt	L Schnitt	NUTEN	Ø Bohrung		PREIS
								STAHL	MESSING	
09961	NIHS-3G	S 0.30	0.080	1.5	30	1.00	3	0.240	0.230	56.90
09962	NIHS-3G	S 0.35	0.090	1.5	30	1.50	3	0.280	0.280	56.90
09963	NIHS-3G	S 0.40	0.100	1.5	30	2.0	3	0.330	0.320	56.90
09964	NIHS-3G +	S 0.40	0.100	1.5	30	2.50	3	0.330	0.320	56.90
09965	NIHS-3G	S 0.50	0.125	1.5	30	2.50	3	0.430	0.400	54.30
09966	NIHS-3G +	S 0.50	0.125	1.5	30	3.50	3	0.430	0.400	54.30
09967	NIHS-3G	S 0.60	0.150	1.5	30	3.00	3	0.510	0.490	51.60
09968	NIHS-3G +	S 0.60	0.150	1.5	30	4.00	3	0.510	0.490	51.60
09969	NIHS-3G	S 0.70	0.175	1.5	30	3.00	3	0.590	0.570	48.90
09970	NIHS-3G +	S 0.70	0.175	1.5	30	4.00	3	0.590	0.570	48.90
09972	NIHS-3G	S 0.80	0.200	1.5	30	3.50	3	0.670	0.650	48.90
09973	NIHS-3G +	S 0.80	0.200	1.5	30	4.00	3	0.670	0.650	48.90
09975	NIHS-3G	S 0.90	0.225	1.5	30	4.00	3	0.750	0.730	48.90
09976	NIHS-3G +	S 0.90	0.225	1.5	30	4.00	3	0.750	0.730	48.90
09978	NIHS-3G	S 1.00	0.250	1.5	30	4.00	3	0.830	0.810	48.90
09979	NIHS-3G +	S 1.00	0.250	1.5	30	4.00	3	0.830	0.810	48.90
09981	NIHS-3G	S 1.20	0.250	1.5	30	5.00	3	1.030	1.010	48.90
09984	NIHS-3G	S 1.40	0.300	1.5	30	5.00	3	1.190	1.170	48.90
09986	ISO2 6H	M 1.50	0.300	2.0	38	6.00	3	1.280	1.260	51.60
09987	ISO2 6H	M 2.00	0.400	2.5	43	11.00	3	1.680	1.650	54.30

Verkaufsbedingungen: Rabatt: 5% für 10 Stück pro Sorte.
10% für 30 Stück pro Sorte.
15% für 50 Stück pro Sorte.



Schurch Asco SA



Partenaire et Savoir-faire

AV. DU 1ER MARS 33, CP 3052
CH-2001 NEUCHÂTEL
SUISSE

TÉL : +41 32 724 3434

FAX : +41 32 724 3436

EMAIL : INFO@SCHURCH-ASCO.COM

WEB : WWW.SCHURCH-ASCO.COM

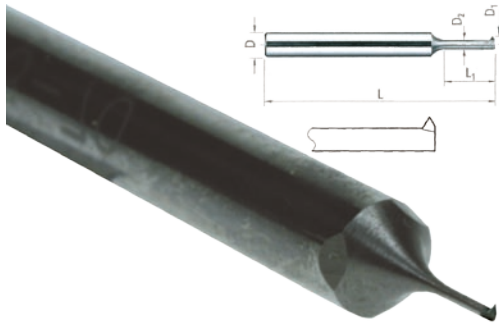

Schafffräser Teilprofil

1739 Z1 HM

Für Edelstahl, Weichmessing (nicht für normales Messing geeignet), Kupfer, Silber, Aluminium, Gold etc.

Schaftdurchmesser: 3 mm

Länge L = 38 mm

Kerntoleranz = h6

Ref.	Ø Gewinde	STEIGUNG	Ø Bohrung	D1	D H ⁵	L1	L	D2	PREIS
16140	S 0.30	0.080	0.23	0.21	3	0.70	38	0.12	62.20
16141	S 0.40	0.100	0.32	0.29	3	0.90	38	0.18	62.20
16142	S 0.50	0.125	0.40	0.37	3	1.20	38	0.23	62.20
16143	S 0.60	0.150	0.48	0.44	3	1.50	38	0.27	62.20
16144	S 0.70	0.175	0.56	0.52	3	1.80	38	0.32	56.70
16145	S 0.80	0.200	0.64	0.59	3	2.00	38	0.36	56.70
16146	S 0.90	0.225	0.72	0.67	3	2.20	38	0.41	56.70
16147	S 1.00	0.250	0.80	0.74	3	2.40	38	0.46	56.70
16148	S 1.20	0.250	1.00	0.94	3	3.00	38	0.66	56.70
16149	S 1.40	0.300	1.15	1.08	3	3.30	38	0.74	56.70

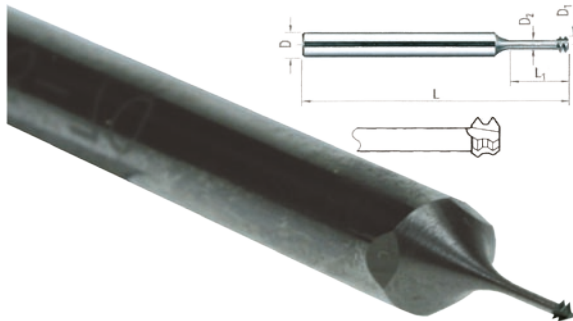

Schafffräser Vollständiges Profil

1730-2D Z3 HM

Für Edelstahl, Weichmessing (nicht für normales Messing geeignet), Kupfer, Silber, Aluminium, Gold etc.

Schaftdurchmesser: 3 mm

Länge L = 38 mm

Kerntoleranz = h6

Ref.	Ø Gewinde	STEIGUNG	D1	D H ⁵	L1	L	D2	PREIS
16150	M 0.90	0.225	0.64	3	2.10	38	0.29	89.40
16151	M 1.00	0.25	0.73	3	2.30	38	0.32	86.40
16152	M 1.20	0.25	0.92	3	2.80	38	0.51	86.40
16153	M 1.40	0.30	1.05	3	3.20	38	0.58	83.60
16154	M 1.60	0.35	1.21	3	3.70	38	0.64	83.60
16155	M 1.80	0.35	1.41	3	4.10	38	0.84	83.60
16156	M 2.00	0.40	1.55	3	4.60	38	1.10	81.60
16157	M 2.20	0.45	1.72	3	5.10	38	0.96	87.30
16158	M 2.50	0.45	2.00	3	5.80	38	1.26	87.30
16159	M 1.80	0.20	1.41	3	4.10	38	1.23	83.60
16160	M 2.20	0.20	1.72	3	5.10	38	1.63	87.30
16161	M 2.50	0.25	2.00	3	5.80	38	1.75	87.30
16162	M 2.50	0.35	2.00	3	5.80	38	1.52	87.30

Verkaufsbedingungen: Der Rabatt oder der Zuschlag variiert je nach Menge und Durchmesser der identischen Schäfte der bestellten Artikel.

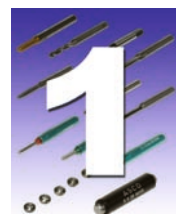

Gewindelehrdorn NT / RT

ASCO HSS

mini und maxi

mit Aluhalter, eloxiert

maxi	mini	Ø Nominal	STEI- GUNG	Ø schaft	PREIS
17620	17600	S 0.30 NT	0.080	4.50	70.00
17621	17601	S 0.35 NT	0.090	4.50	70.00
17622	17602	S 0.40 NT	0.100	4.50	70.00
17623	17603	S 0.50 NT	0.125	4.50	70.00
17624	17604	S 0.60 NT	0.150	4.50	70.00
17625	17605	S 0.70 NT	0.175	4.50	70.00
17626	17606	S 0.80 NT	0.200	4.50	70.00
17627	17607	S 0.90 NT	0.225	4.50	70.00
17628	17608	S 1.00 NT	0.250	4.50	70.00
17629	17609	S 1.10 NT	0.250	4.50	70.00
17630	17610	S 1.20 NT	0.250	4.50	70.00
17631	17611	S 1.30 NT	0.300	4.50	70.00
17632	17612	S 1.40 NT	0.300	4.50	70.00
RT auf Anfrage					

Abmessung: S 0.30 bis M 1.80

Toleranz: NIHS. (Spezialtoleranz auf Anfrage)

maxi = no go = rot

mini = go = grün

Bestellbeispiel : 10 Lehrdorne ASCO mini S 0.8 NIHS-3G



Gewindelehrdorn (S)

ASCO HSS

mini und maxi (nach NIHS Normen) 3G / 4H

mit Aluhalter, eloxiert

maxi	mini	Ø Nominal	STEI- GUNG	Ø schaft	PREIS
02240	01660	S 0.30 3G	0.080	4.50	70.00
02241	01661	S 0.35 3G	0.090	4.50	70.00
02242	01662	S 0.40 3G	0.100	4.50	70.00
02243	01663	S 0.50 3G	0.125	4.50	70.00
02244	01664	S 0.60 3G	0.150	4.50	70.00
02245	01665	S 0.70 3G	0.175	4.50	70.00
02246	01666	S 0.80 3G	0.200	4.50	70.00
02247	01667	S 0.90 3G	0.225	4.50	70.00
02248	01668	S 1.00 3G	0.250	4.50	70.00
02249	01669	S 1.10 3G	0.250	4.50	70.00
02250	01670	S 1.20 3G	0.250	4.50	70.00
02251	01671	S 1.30 3G	0.300	4.50	70.00
02252	01672	S 1.40 3G	0.300	4.50	70.00
02253	01673	S 1.50 3G	0.300	4.50	70.00
02254	01674	M 1.60 6H	0.350	4.50	81.00
02255	01675	M 1.70 6H	0.350	4.50	81.00
02256	01676	M 1.80 6H	0.350	4.50	81.00
4H auf Anfrage					

Abmessung: S 0.30 bis M 1.80

Toleranz: NIHS. (Spezialtoleranz auf Anfrage)

maxi = no go = rot

mini = go = grün

Bestellbeispiel : 10 Lehrdorne ASCO mini S 0.9 NIHS-3G





Schurch Asco SA



Partenaire et Savoir-faire

AV. DU 1ER MARS 33, CP 3052
CH-2001 NEUCHÂTEL
SUISSE

TÉL : +41 32 724 3434

FAX : +41 32 724 3436

EMAIL : INFO@SCHURCH-ASCO.COM

WEB : WWW.SCHURCH-ASCO.COM

Lehrdorn maxi H5	Lehrdorn maxi H6	für Ø	Ø Aluschaft	PRIX
16400	16426	S 0.30 3G	4.50	39.00
16401	16427	S 0.35 3G	4.50	
16402	16414	S 0.40 3G	4.50	
16403	16415	S 0.50 3G	4.50	
16404	16416	S 0.60 3G	4.50	29.80
16405	16417	S 0.70 3G	4.50	
16406	16418	S 0.80 3G	4.50	
16407	16419	S 0.90 3G	4.50	
16408	16420	S 1.00 3G	4.50	
16409	16421	S 1.10 3G	4.50	
16410	16422	S 1.20 3G	4.50	
16411	16423	S 1.30 3G	4.50	
16412	16424	S 1.40 3G	4.50	
16413	16425	S 1.50 3G	4.50	

Glatter Lehrdorn

ASCO HSS

maxi (nach NIHS Normen)

für Kernkontrolle

Messing H5 / Stahl H6

Abmessung: S 0.30 bis S 1.50

Toleranz: NIHS. (Spezialtoleranz auf Anfrage)

Bestellbeispiel:

10 Lehrdorne ASCO maxi S 0.8 rot H5



Gewindelehrdorn

FRAISA, HM

mini und maxi NIHS

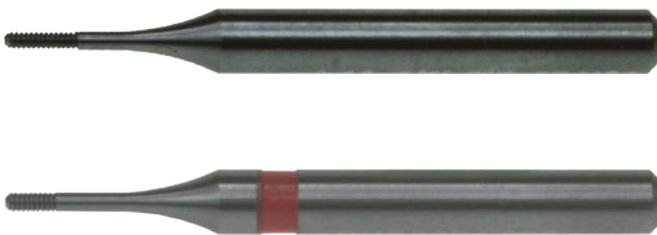

Abmessung: S 0.30 à S 1.00

Toleranz: NIHS. (Spezialtoleranz auf Anfrage)

Messprotokoll auf Anfrage.

mini = go = ohne rot

maxi = no go = rot

Bestellbeispiel : 10 Lehrdorne FRAISA mini S 0.8 3G



Die Lieferung schliesst eine Bescheinigung über die Genauigkeit der Lehrdorne, sowie das Messprotokoll ein und wird berechnet mit **Fr. 27.50**.

Ohne ausdrücklichen Wunsch werden die Lehrdorne ohne Bescheinigung geliefert.

Lehrdorn maxi	Lehrdorn mini	Ø Nominal	STEIGUNG	Ø Aluschaft	PREIS
16700	16720	S 0.30 3G	0.080	3.00	79.00
16701	16721	S 0.35 3G	0.090	3.00	79.00
16702	16722	S 0.40 3G	0.100	3.00	79.00
16703	16723	S 0.50 3G	0.125	3.00	79.00
16704	16724	S 0.60 3G	0.150	3.00	79.00
16705	16725	S 0.70 3G	0.175	3.00	79.00
16706	16726	S 0.80 3G	0.200	3.00	79.00
16707	16727	S 0.90 3G	0.225	3.00	79.00
16708	16728	S 1.00 3G	0.250	3.00	79.00
16729		Überprüfung eines Lehrdorns nach Gebrauch + Bescheinigung			44.00

Verkaufsbedingungen: Rabatt: 10% pro Bestellung von 10 identische Teile.

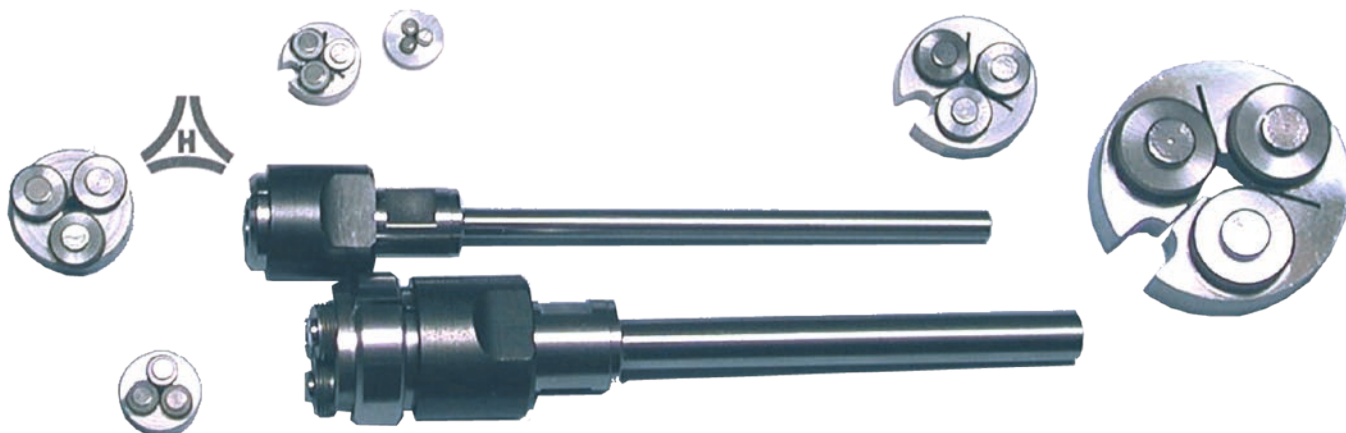

Ref.	Ø Nominal	D	H	TYP	PREIS
16641	0.35	6	2	N6	46.05
16642	0.40	6	2	N6	46.05
16643	0.50	6	3	N6	46.05
16644	0.60	6	3	N6	41.70
16645	0.70	6	3	N6	41.70
16646	0.80	8	5	N8	38.65
16647	0.90	8	5	N8	38.65
16648	1.00	8	5	N8	38.65
16649	1.10	8	5	N8	38.65
16650	1.20	8	5	N8	38.65
16651	1.30	8/10	6	N8	47.45
16652	1.40	8/10	6	N8	47.45
16653	1.50	8/10	6	N8	47.45
16654	1.60	12	6	N12	59.25
16655	1.70	12	6	N12	59.25
16656	1.80	12	6	N12	59.25
16657	2.00	12	6	N12	59.25
16658	2.20	12/16	8	N12	69.45
16659	2.50	12/16	8	N12	69.45
16660	2.60	12/16	8	N12	69.45
16661	PM 3.00	12/16	8	N12	69.45
16662	3.00	22	11	F8	99.05
16663	3.50	22	11	F8	99.05
16664	4.00	22	11	F8	99.05
16665	5.00	25	13	F8	125.60
16666	6.00	30	16	V10 / F10	140.45

Gewinderolleisen nicht einstellbar

Gewinderolleisen aus Stahl HSS 5h3 für das Rollen von Schrauben und Gewinden.

Der Außendurchmesser wird durch den Drehdurchmesser bestimmt.

Die Rolleisen sind in 10tel Mikrometern erhältlich.

Beispiel: Durchmesser 0.80, 0.79, 0.78, 0.77

Von der Tabelle abweichende Durchmesserwerte sind bei der Bestellung anzugeben.

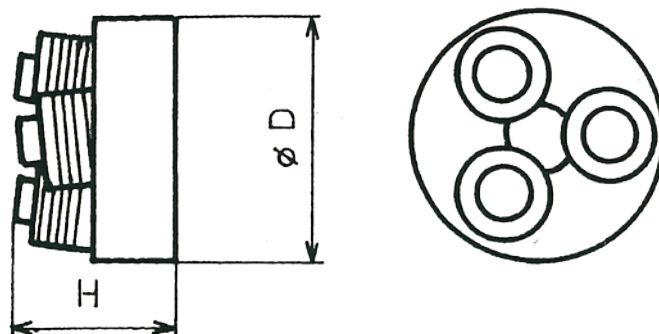

Verkaufsbedingungen: Rabatt:

3 % pro Bestellung von 20 bis 49 Stück pro Sorte.

5% pro Bestellung von 50 bis 99 Stück pro Sorte.

8% pro Bestellung von 100 Stück pro Sorte oder mehr.



Schurch Asco SA



Partenaire et Savoir-faire

AV. DU 1ER MARS 33, CP 3052
CH-2001 NEUCHÂTEL
SUISSE

TÉL : +41 32 724 3434

FAX : +41 32 724 3436

EMAIL : INFO@SCHURCH-ASCO.COM

WEB : WWW.SCHURCH-ASCO.COM

Gewinderolleisen, einstellbar

Rolleisen aus Stahl HSS 5h3, günstig und empfohlen für kleine Serien.

Der Aussendurchmesser wird durch den Drehdurchmesser bestimmt.

Die Gewinde sind in 10 Mikrometern erhältlich.

Beispiel : Durchmesser 0.80, 0.79, 0.78, 0.77

Von der Tabelle abweichende Durchmesserwerte sind bei der

Bestellung genau anzugeben.

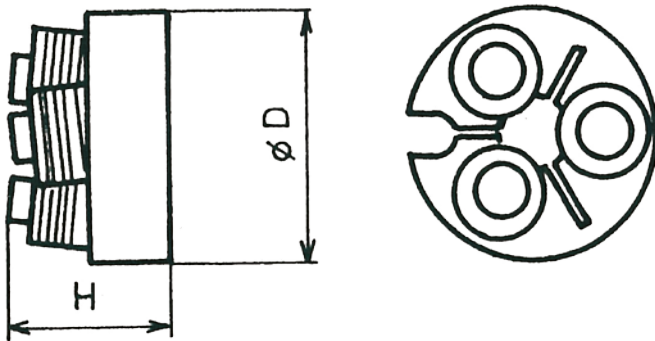

Ref.	Ø Nominal	D	H	TYP	PREIS
16600	0.60	8.00	3.00	R8	51.20
16601	0.70	8.00	3.00	R8	51.20
16602	0.80	8.00	5.00	R8	46.90
16603	0.90	8.00	5.00	R8	46.90
16604	1.00	10.00	5.00	R10	46.90
16605	1.10	10.00	5.00	R10	46.90
16606	1.20	10.00	5.00	R10	46.90
16607	1.30	10.00	6.00	R10	58.50
16608	1.40	10.00	6.00	R10	58.50
16609	1.50	10.00	6.00	R10	58.50
16610	1.60	14.00	6.00	R14	71.00
16611	1.70	14.00	6.00	R14	71.00
16612	1.80	14.00	6.00	R14	71.00
16613	2.00	14.00	6.00	R14	71.00
16614	2.20	16.00	8.00	R16	85.40
16615	2.50	16.00	8.00	R16	85.40
16616	2.60	16.00	8.00	R16	85.40
16617	PM 3.00	16.00	8.00	R16	85.40
16618	3.00	25.00	11.00	R25	121.00
16619	3.50	25.00	12.00	R25	121.00
16620	4.00	25.00	12.00	R25	121.00
16621	4.50	25.00	12.00	R25	151.00
16622	5.00	27.00	13.00	R27	151.00
16623	6.00	32.00	16.00	R32	169.20
16624	8.00	35.00	20.00	R35	313.55

Schneideisenhalter, einstellbar

für Schneideisen, einstellbar

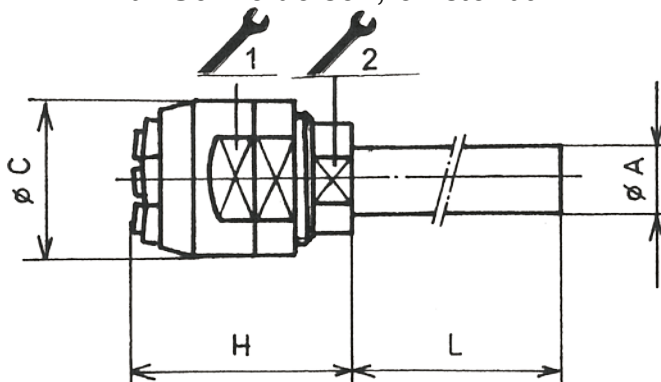

Ref.	L	H _{max}	C	1	2	TYP	PREIS
16625	55	21	13.0	11	5.5	R8	93.95
16626	55	22	15.0	13	9	R10	93.95
16627	55	22	16.5	15	9	R12	93.95
16628	55	22	19.0	17	9	R14	93.95
16629	55	24	22.0	19	13	R16	93.95
16630	55	28	26.0	22	15	R18	93.95
16631	55	32	32.0	8025	17	R25	153.60
16632	55	33	35.0	8027	19	R27	153.60
16633	55	37	40.0	8032	22	R32	153.60
16634	55	42	45.0	8035	27	R35	184.80

Verkaufsbedingungen: Rabatt : 3 % pro Bestellung von 20 bis 49 Stück pro Sorte.
5 % pro Bestellung von 50 bis 99 Stück pro Sorte.
8 % pro Bestellung von 100 Stück pro Sorte oder mehr.

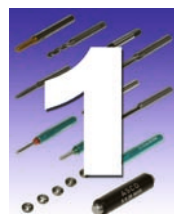

Schneideisenhalter, nicht einstellbar für Schneideisen, nicht einstellbar

Ref.	L	H _{max}	C	1	2	TYP Ø _A	PREIS
16667	53	24	12	9	5.5	N6-3	79.75
16668	53	24	12	9	5.5	N6-5	79.75
16669	53	27	12	9	5.5	N8-3	79.75
16670	53	27	12	9	5.5	N8-5	79.75
16671	46	33	14	12	7.5	N12-3	93.95
16672	46	33	14	12	7.5	N12-5	93.95

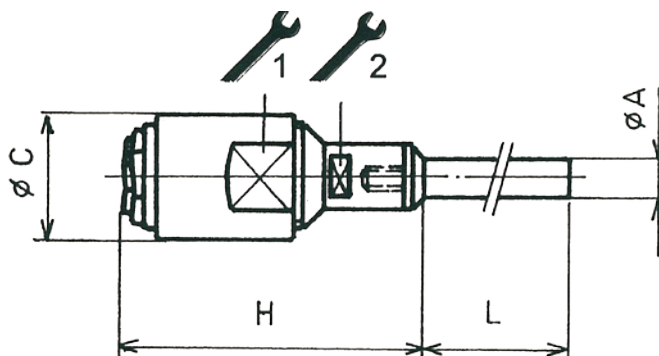

Schneideisenhalter, nicht einstellbar für Schneideisen, nicht einstellbar

Ref.	L	H _{max}	C	TYP Ø _A	PREIS
16673	30	37	14	F8-5	54.10
16674	15	18	14	F8-6	54.10
16675	30	18	14	F8-7	54.10
16676	50	18	14	F8-8	54.10
16677	60	39	29	V10-8	82.60
16678	70	39	29	V10-10	82.60
16679	30	25	29	V10-14	82.60

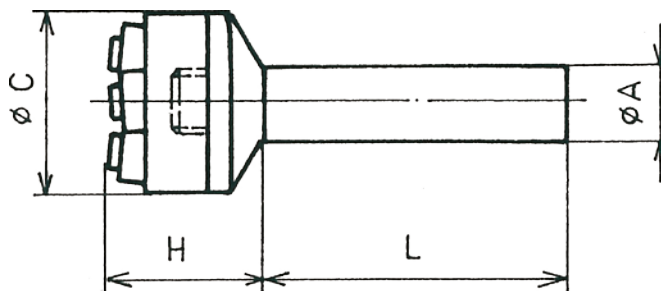

Konus für Schneideisenhalter

Die Montage auf die Maschine wird mit einer Spannzange vorgenommen oder in der Zangenaufnahme mit Hilfe eines Spannkegels.

Ref.	D	I	α°	TYP Ø _A	PREIS
16680	10.7	7	15	CPF7	45.80
16681	12.0	7	16	CPF7-12	45.80
16682	12.0	8	16	CPF8	45.80
16683	15.5	10	20	CPF10	45.80
16684	18.0	12	16	CPF12	45.80
16685	18.0	14	16	CPF14	98.70
16686	22.0	16	16	CPF16	98.70

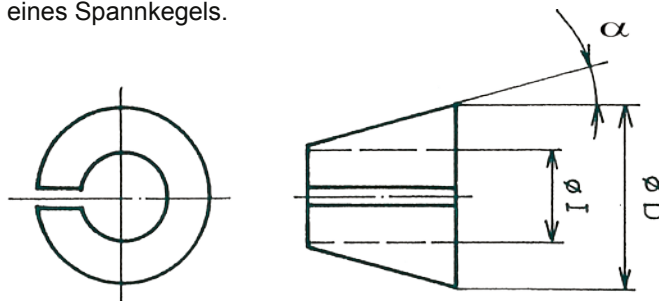

Verkaufsbedingungen: Rabatt: 3 % bei Bestellung von 20 bis 49 Stück pro Sorte.
5 % bei Bestellung von 50 bis 99 Stück pro Sorte.
8 % bei Bestellung von 100 Stück pro Sorte oder mehr.



Schurch Asco SA



Partenaire et Savoir-faire

AV. DU 1ER MARS 33, CP 3052
CH-2001 NEUCHÂTEL
SUISSE

TÉL : +41 32 724 3434

FAX : +41 32 724 3436

EMAIL : INFO@SCHURCH-ASCO.COM

WEB : WWW.SCHURCH-ASCO.COM



Schneideisen ASCO

für Uhrenindustrie und Apparatebau

Werkzeugstahl

Für die Reparatur von beschädigten Schrauben.

Ref.	Ø nominal	STEIGUNG	Ø Aussen	Ø Aussenschaft		PREIS
				MINI	MAXI	
16003	S 0.40	0.100	8.00	0.382	0.400	33.00
16005	S 0.50	0.125	8.00	0.480	0.500	33.00
16019	S 1.30	0.300	8.00	1.265	1.300	33.00
16021	S 1.50	0.300	8.00	1.460	1.500	33.00
16022	M 1.60	0.350	8.00	1.496	1.581	33.00
16023	M 1.70	0.350	8.00	1.596	1.681	33.00
16024	M 1.80	0.350	8.00	1.696	1.781	33.00
16025	M 2.00	0.400	8.00	1.886	1.981	33.00



Schneideisen ASCO HSS

DIN 13/50°/1.8

Diese Schneideisen sind vorgespaltet und die geschlossene Ausführung garantiert eine präzise Wiederholung.

Ref.	Ø nominal	STEIGUNG	Ø Aussen	DICKE	TOLERANZ	PREIS
17535	M 1.00 6h	0.25	16	5	6h	62.40
17536	M 1.10 6h	0.25	16	5	6h	59.30
17537	M 1.20 6h	0.25	16	5	6h	59.30
17538	M 1.40 6h	0.30	16	5	6h	59.30
17539	M 1.60 6g	0.35	16	5	6g	56.70
17540	M 1.70 6g	0.35	16	5	6g	56.70
17541	M 1.80 6g	0.35	16	5	6g	56.20
17542	M 2.00 6g	0.40	16	5	6g	39.20
17543	M 2.20 6g	0.45	16	5	6g	39.20
17544	M 2.30 6g	0.40	16	5	6g	39.20
17545	M 2.50 6g	0.45	16	5	6g	39.20
17546	M 2.60 6g	0.45	16	5	6g	45.80
17547	M 3.00 6g	0.50	20	5	6g	33.00
17548	M 3.50 6g	0.60	20	5	6g	45.80
17549	M 4.00 6g	0.70	20	7	6g	33.00
17550	M 5.00 6g	0.80	20	7	6g	33.00
17551	M 6.00 6g	1.00	20	7	6g	38.50

Verkaufsbedingungen: Nettopreise.

30 Gewindebohrer und Schneideisen

Mai 2023



Lehrdorn - Halter Nr 1

Diese Halter passen zu den Rohlinge-Gewindebohrern und Prüflehren.

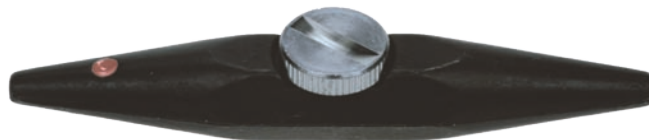

Ref.	Ø	PREIS
00562	1.00 → 2.00	19.30

Gewindelehrringe ASCO HSS

gehen / nicht gehen (nach NIHS Normen) 5h / 4g

mit Aluhalter, eloxiert

Abmessung: S 0.30 bis S 1.80

Spezialtoleranzen auf Anfrage.

Ein Satz Lehrdorne pro Artikel, mini et maxi.



Ref.	Ø _{Nominal}	TOLERANZ	STEIGUNG	Ø _{Aluschaft}	PREIS
02300	S 0.30	NIHS 5h	0.080	4.50	237.00
02301	S 0.35	NIHS 5h	0.090	4.50	237.00
02302	S 0.40	NIHS 5h	0.100	4.50	237.00
02303	S 0.50	NIHS 5h	0.125	4.50	237.00
02304	S 0.60	NIHS 5h	0.150	4.50	237.00
02305	S 0.70	NIHS 5h	0.175	4.50	237.00
02306	S 0.80	NIHS 5h	0.200	4.50	237.00
02307	S 0.90	NIHS 5h	0.225	4.50	237.00
02308	S 1.00	NIHS 5h	0.250	4.50	237.00
02309	S 1.10	NIHS 5h	0.250	4.50	237.00
02310	S 1.20	NIHS 5h	0.250	4.50	237.00
02311	S 1.30	NIHS 5h	0.300	4.50	237.00
02312	S 1.40	NIHS 5h	0.300	4.50	237.00
02313	S 1.50	NIHS 5h	0.300	4.50	237.00
02314	M 1.60	NIHS 6g	0.350	4.50	270.00
02315	M 1.70	NIHS 6g	0.350	4.50	270.00
02316	M 1.80	NIHS 6g	0.350	4.50	270.00

Verkaufsbedingungen: Nettopreise.

April 2022

Gewindebohrer und Schneideisen 31